



Travis County Commissioners Court Agenda Request

Meeting Date: 7/17/2012

Prepared By/Phone Number: George Monnat, 854-9778

Elected/Appointed Official/Dept. Head: Cyd Grimes

Commissioners Court Sponsor: Judge Biscoe

Agenda Language:

Approve contract award for 700 Lavaca External Video Security Cameras, RFP No. P120025-GM, to the most responsive proposer, Knight Security Systems, LLC.

- **Purchasing Recommendation and Comments:** Purchasing concurs with department and recommends approval of requested action. This procurement action meets the compliance requirements as outlined by the statutes.

On November 8, 2011, Request for Proposal No. P120025-GM was issued through Bid Sync for External Video Security Cameras to be installed at 700 Lavaca. A total of five (5) proposals were received on November 30, 2011. After evaluating the proposals and receiving the Best and Final Offers, the committee recommends awarding to Knight Security Systems, LLC as the most qualified respondent, as its proposal meets all county requirements. The cost of the equipment, software, installation, and support services in the first year is \$74,479.22. Extended equipment warranty and maintenance/support for year one is included; and, the cost for extended equipment warranty and maintenance/support for the first and second renewal years is \$10,403.00 per year.

- **Contract-Related Information:**

Award Amount: \$74,479.22

Contract Type: Purchase/Installation

Contract Period: Life of the System

AGENDA REQUEST DEADLINE: All agenda requests and supporting materials must be submitted as a pdf to Cheryl Aker in the County Judge's office, Cheryl.Aker@co.travis.tx.us by Tuesdays at 5:00 p.m. for the next week's meeting.

➤ **Special Contract Considerations:**

- Award has been protested; interested parties have been notified.
- Award is not to the lowest bidder; interested parties have been notified.
- Comments:

Funding Information:

- Purchase Shopping Cart in SAP: 1000001786
- Funding Account(s): Shopping Cart
- Comments:

AGENDA REQUEST DEADLINE: All agenda requests and supporting materials must be submitted as a pdf to Cheryl Aker in the County Judge's office, Cheryl.Aker@co.travis.tx.us by Tuesdays at 5:00 p.m. for the next week's meeting.

FACILITIES MANAGEMENT DEPARTMENT

Roger A. El Khoury, M.S., P.E., Director



1010 Lavaca Street, Suite 400 • P.O. Box 1748, Austin, Texas 78767 • Phone: (512) 854-9661 • Fax: (512) 854-9226

MEMORANDUM

FMD Project: LAVA7-59-12R-4R
File: 703

TO: Cyd V. Grimes, C.P.M., Purchasing Agent

FROM: Roger A. El Khoury, M.S., P.E., Director

DATE: May 03, 2012

SUBJECT: 700 Lavaca Building
External Video Security Cameras

A handwritten signature in blue ink, reading "Roger A. El Khoury", is positioned to the right of the "FROM:" field.

Facilities Management Department (FMD) recommends award of the External Video Security Cameras in the amount of \$74,479.22 to the most qualified bidder Knight Security Systems contractor's bid on the subject project.

FMD has reviewed the bid tabulation and the most qualified bid is fair and reasonable. FMD is recommending award of the base bid and option item. The construction schedule is 15 calendar days after the issuance of the notice to proceed. The project fund is located in account number 001-1405-525-8105 and the requisition number is 558449, with commodity code 909, and sub-commodity code 055.

In accordance with the procedure to secure approval for this contract award, this request is being forwarded along with the supporting documents for approval by the Commissioners Court. If approved, please issue a fully executed contract to Knight Security Systems. Please call Kim Nguyen at extension 45967 if you have any questions.

ATTACHMENT:
Bid Tabulation Form

COPY TO:

Leslie Browder, County Executive, PBO
Amy Draper, CPA, Financial Manager, FMD
Kim Nguyen, AIA, LEED AP, Sr. Architectural Associate, FMD
George Monnat, Purchasing Agent Assistant IV, TCPO

**CONTRACT BETWEEN TRAVIS COUNTY AND
KNIGHT SECURITY SYSTEMS, LLC FOR EXTERNAL VIDEO SECURITY
CAMERAS FOR THE TRAVIS COUNTY 700 LAVACA OFFICE BUILDING AND
GARAGE**

This Contract between Travis County and Knight Security Systems, LLC for External Video Security Cameras for the Travis County 700 Lavaca Office Building and Garage (this "Contract") is entered into by and between the following parties: Travis County, a political subdivision of the State of Texas ("County") and Knight Security Systems, LLC, a Texas limited liability company ("Contractor").

County requested proposals from qualified companies for the procurement and installation of external video security cameras and associated equipment and services for the Travis County 700 Lavaca Office Building and Garage (collectively, the "Systems and Services") pursuant to Request for Proposal #P120025-GM and its amendments, modifications and addenda (the "RFP") and all requirements, specifications, terms and conditions specified in the RFP; and

Contractor was the successful proposer under the RFP.

NOW, THEREFORE, in consideration of the mutual covenants set forth in this Contract and other good and valuable consideration, the receipt and sufficiency of which are acknowledged, the parties agree as follows:

1.0 CONTRACT PROJECT, PURPOSE AND PRICING SCHEDULE

1.1 The purpose of this Contract is to procure external security cameras at the Travis County-owned commercial office building located at 700 Lavaca Street, Austin, Texas, that satisfy or exceed the requirements set forth in RFP# P120025-GM. Contractor's obligations with respect to delivery, installation, configuration, implementation and maintenance of the Systems and Services will be as set forth in this Contract and its attachments, as may be amended from time to time.

1.2 County's obligations with respect to payment for the Systems and Services will be as set forth in Contractor's Best and Final Offer in Response to RFP #P120025-GM, dated May 3, 2012, a copy of which is attached to this Contract as **Attachment A** (entitled "Best and Final Offer (BAFO); RFP #P120025-GM: Pricing Schedule").

2.0 CONTRACTOR OBLIGATIONS

2.1 Contractor shall, in a timely manner, install, configure, implement and maintain the Systems and provide the services described in RFP# P120025-GM and in this Contract and its attachments in accordance with their terms and conditions, and in compliance with the assurances, certifications, and all other statements made by

Contractor in its Proposal in Response to RFP# P120025-GM, attached as **Attachment B** (the "Proposal"). All hardware, software and services (or components thereof) provided under this Contract must be the latest improved model meeting specifications in current production at the time of delivery.

2.2 Contractor acknowledges and agrees that this Contract includes pricing for all required hardware, software, configuration, installation, implementation, training, accessories, and System warranty and maintenance.

2.3 The System shall be secure, comply with all Travis County Information Security Requirements, and provide appropriate levels of confidentiality, integrity, availability and non-repudiation, as such terms are defined in Section 35 of the General Provisions (**Attachment C**). The System must also meet or exceed all federal, state and local government laws and regulations, governing the creation, use, storage, access, accessibility, maintenance, processing and transmission of information assets.

3.0 TERM OF CONTRACT; PERFORMANCE PERIOD

3.1 Term of Contract. The term of this Contract will begin upon award by the Travis County Commissioners Court (the "Commissioners Court") and, unless sooner terminated as provided in this Contract, will continue in full force and effect: (i) with respect to the Systems, for life of the Systems, and (ii) with respect to the Services, through successful completion of the Services.

3.2 Performance Period. Contractor shall complete staged installation of the Systems and performance of the Services in all 700 Lavaca locations identified on Attachment F to this Contract so that they are fully tested, operational and functioning in accordance with the Performance Criteria exclusive of the Acceptance Test Period (as defined in paragraph 4.4, below) no later than September 24, 2012 (the "Completion Date"). The first stage installation shall include priority cameras labeled as locations #1, 2, 9, 10, 13, and 14 of Attachment F-1 and locations #A, B, C, and D of Attachment F-2, for which installation shall be completed by no later than August 31, 2012. The final installment shall include the remaining cameras located at sites #3, 4, 5, 6, 7, 8, 11, and 12 of Attachment F-1. The Completion Date is contingent upon receipt of purchase order from County no later than July 23, 2012. If Contractor fails to achieve completion by the Completion Date, Contractor, by execution of this Contract, specifically acknowledges that County will sustain damages for each day the completion extends beyond the Completion Date. Because of the impracticality and extreme difficulty of fixing and ascertaining County's actual damages, Contractor agrees that \$100.00 per calendar day shall be deducted by County from any amounts due Contractor for every day that the Contractor's installation of the Systems and performance of the Services extends beyond the Completion Date.

3.3 Time is of the essence in the rendering of the Services under this Agreement.

4.0 SCOPE AND TERM OF WARRANTY

4.1 Contractor shall provide the following warranties on the Systems and Services:

[i] First-year Warranty: For the first year following Acceptance, Contractor shall provide all warranty and maintenance services described in Contractor's Service Level Agreement entitled "Knight Security Systems SecurePlan Administration Policy dated January 1, 2012", attached to this Contract as **Attachment D**.

[ii] Second-year Warranty: Upon expiration of the first-year warranty, County may, at its option, purchase the Extended Equipment Warranty for a second year of Service Level Agreement coverage for the sum specified in **Attachment E**.

4.2 Commencement of Warranty. All warranties will begin after installation, configuration, testing and Acceptance by County. "Acceptance" is defined and described in Section 3.4, below.

4.3 Cap on Maintenance Fees Increases. For each year after the above-specified warranty periods (First-Year Warranty and Second-Year Warranty) during which County accepts continued warranty and maintenance services under a Service Level Agreement, the annual warranty and maintenance fee will not increase more than five percent (5%) annually over the prior year's warranty and maintenance fee.

4.4 Performance Criteria; Acceptance. For the warranty periods specified above, the Systems will conform to applicable functional and performance requirements and specifications furnished either by County or by Contractor and incorporated by reference into this Contract (collectively, the "Performance Criteria"). "Acceptance" of each System or System component delivered to County will occur when County provides Contractor with written notice that the System or System component (i) has been successfully installed (ready for testing and configuration); and (ii) has performed in accordance with the Performance Criteria for a period of fourteen (14) days (the "Acceptance Test Period").

4.5 Notice of Warranty Failure and Remedies. During the warranty period, in the event any System or System component fails to function in accordance with the Performance Criteria, County may notify Contractor of such failure and Contractor shall, at no cost to County, repair or replace the defective System (or defective System component) so that the System will perform in accordance with the Performance Criteria. In addition, if any System or System component fails to function in accordance with the Performance Criteria at any time during the Acceptance Test Period, Contractor

shall have 14 days after written notice to remedy or replace the failed component after which period Contractor shall remove the non-functioning component and refund to County the amount paid to Contractor for the non-functioning component. The refund shall be mailed to County within forty-five (45) days of receipt of a written request for such refund from County. Return of non-performing merchandise and delivery of replacement merchandise shall be at Contractor's sole expense.

5.0 CONTRACTOR REPRESENTATIONS AND WARRANTIES; IMPLIED SERVICES

5.1 Contractor warrants that he has thoroughly examined the general and specific requirements, schedules, instructions and all other Contract documents. Contractor has made all investigations necessary to be thoroughly informed regarding the requirements for materials, equipment and/or services as required by the RFP. Further, Contractor warrants that Contractor is fully satisfied that the RFP specifications accurately describe or indicate that all conditions, site or otherwise, have been taken into account in determining the offered prices. There will be no increase in the quoted Contract prices based upon Contractor's misunderstanding or lack of knowledge about the intent of the RFP solicitation.

5.2 Contractor warrants that all of the information provided in the BAFO and its original Proposal in Response to RFP # P120025-GM is true and correct and that Contractor will use its best efforts to provide quality Systems and Services to County, and associated training, maintenance and support services to County. Specifically, this warranty extends to all statements and/or representations made by Contractor in its Proposal.

5.3 Contractor warrants that all system services and products provided to County under this Contract will be fully tested, and ready for installation. Contractor further warrants that all hardware, software, and accessories provided under this Contract will function correctly, without error or omissions, and at no additional cost to County.

5.4 Contractor acknowledges and agrees that if any services, functions or responsibilities not specifically described in this Contract are required for the proper performance and provision of the Systems and Services, they shall be deemed to be implied by and included within the scope of this Contract to the same extent and in the same manner as if specifically described in this Contract. Except as otherwise expressly provided in this Contract, Contractor shall be responsible for providing the facilities, personnel and other resources as necessary to perform and provide the Systems and Services.

5.5 Contractor warrants that (i) all applicable copyrights, patents, trade secrets, licenses and other proprietary and intellectual property rights that may exist on materials used in this Contract have been adhered to and (ii) County shall not be liable

for any infringement of those rights and any rights granted to County shall apply for the duration of this Contract. In connection with this warranty, Contractor agrees to and shall indemnify County, its officers, agents and employees from all claims, losses, damages, causes of action and liability of every kind including expenses of litigation, court costs and attorney fees for damages to any person or property arising in connection with any alleged or actual infringement of existing copyrights, patents, trade secrets, licenses and other proprietary or intellectual property rights applicable to materials used in this Contract, unless such infringement is a result of activities undertaken by the County with no involvement from Contractor. In the event that an infringement suit or proceeding arises, Contractor shall, at its sole cost and expense, secure County's right to continue using the System, and all products and services provided under this Contract or replace or modify all or part of the System, or product or service to render it noninfringing.

6.0 PRICING; PURCHASE ORDER; CONTRACT ADMINISTRATION

6.1 Pricing. Contractor represents that all prices quoted in the BAFO shall be firm for the period of this Contract; provided, however, that in the event of a general price decline offered by Contractor to all customers, County will receive a pro-rated reduction equivalent to that offered to customers of similar products.

6.2 Purchase Order. Contractor will not release any items or perform any services until a purchase order number is assigned by the designated representative of the County Purchasing Office. Contractor will reference contract and purchase order on all invoices submitted to the Travis County Auditor. Upon issuance of a purchase order, the contract administrator will call Contractor with the items needed to be supplied. Contractor must respond by supplying the items at the time required. Failure to act in this manner may result in termination of this Contract.

6.3 Contract Administrator. For purposes of monitoring performance, establishing requirements, approving and coordinating schedules, users and equipment, the County department named below shall act as Contract administrator on behalf of Travis County:

Travis County Information Technology Services
Attention: Frank Esparza
700 Lavaca, Suite 500
Austin, Texas 78701
(512) 854-5226

7.0 ATTACHMENTS

7.1 The attachments enumerated below, in addition to all requirements, specifications, terms and conditions set forth in this Contract, are made a part of this

Contract for all purposes, and constitute promised performances by Contractor in accordance with Section 2.0 of this Contract:

- (i) Attachment A: Best and Final Offer in Response to RFP #P120025-GM
- (ii) Attachment B: Contractor's Proposal
- (iii) Attachment C: General Provisions
- (iv) Attachment D: Knight Security Systems SecurePlan Administration Policy dated January 1, 2012
- (iv) Attachment E: Knight Security Systems Extended Equipment Warranty
- (v) Attachment F: Specific Requirements
- (vi) Attachment G: Question and Answers for Bid # P120025-GM – External Video Security Cameras (History) dated November 28, 2011
- (vii) Attachment H: Ethics Affidavit
- (viii) Attachment I: Non-Disclosure and Confidentiality Agreement for Documents Comprising ITS Security Requirements

7.0 ENTIRE CONTRACT

7.1 This Contract represents the final written agreement between the parties with respect to the subject matter herein and supersedes any and all prior negotiations, representations, or agreements, either oral or written.

8.0 ORDER OF PRECEDENCE

8.1 In the event of inconsistency between the documents comprising this Contract, or any clauses contained in those documents, the inconsistency will be resolved by giving precedence in the following ascending order:

- Sections 1 through 8 of this Contract
- Contractor's BAFO
- Specific Requirements
- General Provisions
- Travis County Request for Proposal #P120025-GM
- Contractor's Proposal in Response to RFP # P120025-GM
- Knight Security Systems Customer System Agreement (Scope of Work)
- Knight Security Systems SecurePlan Administration Policy
- Knight Security Systems Extended Equipment Warranty
- Question and Answers for Bid # P120025-GM – External Video Security Cameras (History) dated November 28, 2011
- Other provisions, whether incorporated by reference or otherwise

IN WITNESS WHEREOF, the parties have executed this Contract as of the date(s) set forth below. The effective date of this Contract (the "Effective Date") shall for all purposes be the date of the execution of the last to sign, whether County or Contractor.

TRAVIS COUNTY, TEXAS:

By: _____
Samuel T. Biscoe
Travis County Judge

Date: _____

KNIGHT SECURITY SYSTEMS, LLC

By: _____

Name: _____

Title: _____

Date: _____

APPROVED AS TO FORM:

County Attorney

Attachment A

Best and Final Offer in Response to RFP #P120025-GM

Attachment B

Contractor's Proposal in Response to RFP #P120025-GM

Attachment C

GENERAL PROVISIONS

1.0 GENERAL DEFINITIONS:

- 1.1 "Auditor" means the Travis County Auditor or her designee.
- 1.2 "Commissioners Court" means Travis County Commissioners Court.
- 1.3 "County" means Travis County, Texas, a political subdivision of the State of Texas.
- 1.4 "County Building" means any County owned buildings and does not include buildings leased by County.
- 1.4 "Is doing business" and "has done business" mean:
 - 1.4.1 Paying or receiving in any calendar year any money or other valuable thing which is worth more than \$250 in the aggregate in exchange for personal services or for purchase of any property or property interest, either real or personal, either legal or equitable; or
 - 1.4.2 Loaning or receiving a loan of money; or goods or otherwise creating or having in existence any legal obligation or debt with a value of more than \$250 in the aggregate in a calendar year;but does not include:
 - 1.4.3 any retail transaction for goods or services sold to a Key Contracting Person at a posted, published, or marked price available to the general public;
 - 1.4.4 any financial services product sold to a Key Contracting Person for personal, family or household purposes in accordance with pricing guidelines applicable to similarly situated individuals with similar risks as determined by Contractor in the ordinary course of its business; and
 - 1.4.5 a transaction for a financial service or insurance coverage made on behalf of Contractor if Contractor is a national or multinational corporation by an agent, employee or other representative of

Contractor who does not know and is not in a position that he or she should have known about this Agreement.

1.5 "Key Contracting Person" means any person or business listed in Exhibit A to the Ethics Affidavit attached as Contract Exhibit H.

1.6 "Historically Underutilized Business" or "HUB" means any entity or association formed to make a profit in which one (1) or more persons who are educationally or economically disadvantaged because of their identification as members of one of the following groups: African Americans, Hispanic Americans, Asian Pacific Americans, Native Americans or Women of any ethnicity have the following rights:

1.8.1 own at least fifty-one percent (51%) of all classes of shares or other equitable securities and have incidents of ownership, including an interest in profit and loss, equivalent to the percentage of capital, equipment or expertise contributed to the business where ownership is measured as though the community property interest of a spouse is the separate property of that spouse, if both spouses certify in writing that the non-participating spouse relinquishes control over his or her spouse, and his or her community property, and not as if it is subject to the community property interest of the other spouse; and

1.8.2 have a proportionate interest and demonstrated active participation in the control, operation and management of the business's affairs; where control means having recognized ultimate control over all day-to-day decisions affecting the business, and is be known to, and at least tacitly acknowledged in day-to-day operations by employees of the business and by those with whom business is conducted, and holding a title commensurate with that control.

1.7 "Purchasing Agent" means the Travis County Purchasing Agent.

2.0 **GENERAL CONDITIONS:**

Contractor represents that Contractor has thoroughly examined the drawings, specifications, schedule, instructions and all other Contract documents. Contractor has made all investigations necessary to be thoroughly informed regarding plant and facilities for delivery of material, equipment and/or services as required by the Contract documents.

3.0 CONTRACTOR CERTIFICATIONS:

- 3.1 Contractor certifies that Contractor is a duly qualified, capable, and otherwise bondable business entity, that he is not in receivership or contemplates same, and has not filed for bankruptcy. He further certifies that the company, corporation or partnership is not currently delinquent with respect to payment of property taxes within Travis County.
- 3.2 Contractor warrants that all applicable copyrights and licenses that may exist on materials used in this Contract have been adhered to and further warrants that County will not be liable for any infringement of those rights and any rights granted to County will apply for the duration of this Contract. Contractor shall indemnify County, its officers, agents and employees from all claims, losses, damages, causes of action and liability of every kind including expenses of litigation, and court costs and attorney fees for damages to any person or property arising in connection with any alleged or actual infringement of existing licenses or copyrights applicable to materials used in this Contract.

4.0 DISPUTES AND APPEALS:

The Purchasing Agent acts as the County representative in the issuance and administration of this Contract in relation to disputes. Any document, notice, or correspondence not issued by or to the Purchasing Agent or other authorized County person, in relation to disputes is void unless otherwise stated in this Contract. If Contractor does not agree with any document, notice, or correspondence issued by the Purchasing Agent, or other authorized County person, Contractor must submit a written notice to the Purchasing Agent within ten (10) calendar days after receipt of the document, notice, or correspondence, outlining the exact point of disagreement in detail. If the matter is not resolved to Contractor's satisfaction, Contractor may submit a written Notice of Appeal to Commissioners Court, through the Purchasing Agent, if the Notice is submitted within ten (10) calendar days after receipt of the unsatisfactory reply. Contractor then has the right to be heard by Commissioners Court.

5.0 FUNDING OUT:

Despite anything to the contrary in this Contract, if, during budget planning and adoption, Commissioners Court fails to provide funding for this Contract for the following fiscal year of County, County may terminate this Contract after giving Contractor thirty (30) days written notice that this Contract is terminated due to the failure to fund it.

60 **INVOICING/PAYMENTS:**

- 6.1 Contractor shall provide County with an Internal Revenue Form W-9, Request for Taxpayer Identification Number and Certification, that is completed in compliance with the Internal Revenue Code and its rules and regulations before any Contract funds are payable.
- 6.2 Payment will be made by check or warrant by County upon satisfactory delivery and acceptance of products and services and submission of an invoice to the address below:

County Auditor
P.O. Box 1748
Austin, Texas 78767

- 6.3 As a minimum, invoices must include: (i) name, address, and telephone number of Contractor and similar information in the event payment is to be made to a different address; (ii) County Contract or Purchase Order number; (iii) identification of products or services as outlined in this Contract; (iv) quantity or quantities, applicable unit prices, total prices, and total amount; and (v) any additional payment information called for by this Contract. County will not pay invoices that are in excess of the amount authorized by the Purchase Order.
- 6.4 Payment will be deemed to have been made on the date of mailing of the check or warrant. For purposes of payment discounts, time will begin upon satisfactory delivery of products and services and/or submission of acceptable invoice, whichever is last. Partial payments will not be made unless specifically requested and approved by County prior to Contract award.
- 6.5 Accrual and payment of interest on overdue payments shall be governed by TEX. GOV'T CODE ANN., ch. 2251.

7.0 **DISCOUNTS:**

Prompt payment discounts will not be considered in determining low proposals and making awards. In connection with any discount offered, time will be computed from the date of receipt of supplies or services or from the date a correct invoice is received, whichever is the later date. Payment is deemed to have been made on the date of mailing of the check, or warrant.

8.0 **OFFICIALS NOT TO BENEFIT:**

If a member of the Commissioners Court belongs to a cooperative association, County may purchase equipment or supplies from the association only if no member of the Commissioners Court will receive a pecuniary benefit from the purchase, other than as reflected in an increase in dividends distributed generally to members of the association.

9.0 **COVENANT AGAINST CONTINGENT FEES:**

Contractor warrants that no persons or selling agency has been retained to solicit this Contract upon an understanding for a commission, percentage, brokerage, or contingent fee, excepting bona fide employees or bona fide established commercial selling agencies maintained by Contractor to secure business. For breach or violation of this warranty, County shall have the right to terminate this Contract without liability, or in its discretion to, as applicable, add to or deduct from the Contract price for consideration, or otherwise recover, the full amount of such commission, percentage, brokerage, or contingent fee.

10.0 **ASSIGNMENT OF CONTRACT OR MORTGAGE:**

10.1 Assignment. The parties to this Contract will not assign or transfer any part of this Contract, or any of the rights, interests or obligations under this Contract, directly or indirectly, without the prior written consent and approval of the other party. NO OFFICIAL, EMPLOYEE, REPRESENTATIVE OR AGENT OF COUNTY HAS THE AUTHORITY TO APPROVE ANY ASSIGNMENT OR TRANSFER UNDER THIS CONTRACT UNLESS THAT SPECIFIC AUTHORITY IS EXPRESSLY GRANTED BY COMMISSIONERS COURT.

10.2 Mortgage. Contractor must not execute any mortgage, or issue any bonds, shares of stock or other evidence of interest in County buildings.

10.3 Successors Bound. If an assignment or transfer is made in compliance with the provisions of this Contract, the terms, provisions, covenants, obligations and conditions of this Contract will be binding upon and inure to the benefit of the successors in interest and the assigns of the parties to this Contract.

10.4 Name Change. If a change of name is required, the Purchasing Agent shall be notified immediately. No change in the obligation of or to Contractor will be recognized until it is approved by Commissioners Court.

11.0 **FORCE MAJEURE:**

If the performance by either party of any of its obligations under this Contract is interrupted or delayed by any occurrence not occasioned by its own conduct, whether such occurrence is an act of God or the result of war, riot, civil commotion, sovereign conduct, or the act or conduct of any person or persons not a party to this Contract, then it will be excused from such performance for such period of time as is reasonably necessary after such occurrence to remedy the effects of the force majeure event.

12.0 **TERMINATION FOR DEFAULT:**

Failure by either County or Contractor in performing any provisions of this Contract will constitute a breach of Contract. Either party may require corrective action within ten (10) calendar days after date of receipt of written notice citing the exact nature of the other's breach. Failure to take corrective action or failure to provide a satisfactory written reply excusing such failure within the ten (10) calendar days will constitute a default. The defaulting party will be given a twenty (20) calendar day period within which to show cause why this Contract should not be terminated for default. Commissioner's Court may take whatever action as its interest may appear, resulting from such notice. All notices for corrective action, breach, default or show cause, will be issued by the Purchasing Agent or County Attorney only and all replies shall be made in writing to the Purchasing Agent at the address provided herein. Notices issued by or to anyone other than the Purchasing Agent or County Attorney will be null and void, and will be considered as not having been issued or received. County reserves the right to enforce the performance of this Contract in any manner prescribed by law in case of default and may contract with another party with or without competition or further notification to the Contractor. As a minimum, Contractor will be required to pay any difference in the cost of securing the products or services covered by this Contract, or compensate for any loss or damage to the County derived under this Contract, should it become necessary to contract with another source because of Contractor's default, plus reasonable administrative costs and attorney's fees. In the event of Termination for Default, neither County nor its agents or representatives will be liable for loss of any profits anticipated to be made under this Contract.

13.0 **TERMINATION FOR CONVENIENCE:**

County reserves the right to terminate this Contract upon thirty (30) calendar days written notice for any reason deemed by Commissioners Court to serve the public interest, or resulting from any governmental law, ordinance, regulation, or court order. In the event of such termination, County will pay Contractor those costs directly attributable to work done or supplies obtained in preparation for

completion or compliance with this Contract prior to termination; provided, however, that no costs will be paid that are recoverable in the normal course of doing business in which Contractor is engaged. In addition, no costs that can be mitigated through the sale of supplies or inventories will be paid. If County pays for the cost of supplies or materials obtained for use under this Contract, those supplies or materials will become the property of County and must be delivered to the FOB point shown in this Contract, or as designated by the Purchasing Agent. County will not be liable for loss of any profits anticipated to be made under this Contract.

14.0 **CHANGES:**

14.1 Unless specifically provided otherwise in this Contract, any change to the terms of this Contract or any attachments to it must be made by written change order signed by both parties. The Purchasing Agent may at any time, by written document, make changes within the general scope of this Contract in any one of the following:

14.1.1 Description of services;

14.1.2 Place of delivery;

14.1.3 Any aspect of this Contract to correct errors of a general administrative a nature or other mistakes, the correction of which does not affect the scope of the contract and does not result in expense to Contractor.

14.2 It is acknowledged by Contractor that no officer, agent, employee or representative of County has any authority to change the scope of this Contract or any attachments to it unless expressly granted that authority by the Commissioners Court.

14.3 If any change under 14.1 causes an increase or decrease in the cost or time required for performance of any part of the work under this Contract, the Commissioners Court may make an equitable adjustment in the Contract price, the delivery schedule, or both, and modify this Contract. Contractor must submit any "proposal for adjustment" within thirty (30) calendar days after the date of receipt of the written order.

14.4 Contractor shall submit all requests for alterations, additions or deletions of the terms of this Contract or any attachment to it to the Purchasing Agent. The Purchasing Agent will present Contractor's requests to Commissioners Court for consideration.

15.0 COUNTY ACCESS:

Contractor shall maintain and make available all books, documents, and other evidence pertinent to the costs and expenses of this Contract for inspection, audit or reproduction by any authorized representative of County to the extent this detail will properly reflect these costs and expense. These include all costs; both direct and indirect costs, cost of labor, material, equipment, supplies, and services, and all other costs and expenses of whatever nature for which reimbursement is claimed under this Contract. All required records must be maintained until an audit is completed and all required questions arising therefrom are resolved, or three (3) years after completion of the Contract term, whichever occurs first; however, the records must be retained beyond the third year if an audit is in progress or the findings of a completed audit have not been resolved satisfactorily.

16.0 SUBCONTRACTS:

16.1 Contractor shall not enter into any subcontracts for any service or activity relating to the performance of this Contract without the prior written approval or the prior written waiver of this right of approval from County. It is acknowledged by Contractor that no officer, agent, employee or representative of County has the authority to grant such approval or waiver unless expressly granted that specific authority by the Commissioners Court.

16.2 If a subcontract is approved, Contractor must make a "good faith effort" to take all necessary and reasonable steps to ensure HUBs maximum opportunity to be subcontractors under this Contract. Contractor must obtain County approval of all proposed HUB subcontractors through the Purchasing Agent. Failure by Contractor to make a good faith effort to employ HUBs as subcontractors constitutes a breach of this Contract and may result in termination of this Contract.

19.0 MONITORING:

County reserves the right to perform periodic on-site monitoring of Contractor's compliance with the terms of this Contract, and of the adequacy and timeliness of Contractor's performance under this Contract. After each monitoring visit, County will provide Contractor with a written report of the monitor's findings. If the report notes deficiencies in Contractor's performances under the terms of this Contract, it will include requirements and deadlines for the correction of those deficiencies by Contractor. Contractor shall take action specified in the monitoring report prior to the deadlines specified.

20.0 CIVIL RIGHTS/ADA COMPLIANCE:

Contractor shall provide all services and activities required by this Contract in a manner that would comply with the Civil Rights Act of 1964, as amended, the Rehabilitation Act of 1973, Public Law 93-1122, Section 504, and with the provisions of the Americans With Disabilities Act of 1990, Public Law 101-336 [S.933] if Contractor were an entity bound to comply with these laws. Contractor shall not discriminate against any employee or applicant for employment based on race, religion, color, sex, national origin, age or handicapped condition.

21.0 GRATUITIES:

County may terminate this Contract if it is found that gratuities of any kind including entertainment, or gifts were offered or given by Contractor or any agent or representative of the Contractor, to any County official or employee with a view toward securing favorable treatment with respect of this Contract. If this Contract is terminated by County pursuant to this provision, County shall be entitled, in addition to any other rights and remedies, to recover from Contractor at least three times the cost incurred by Contractor in providing the gratuities.

22.0 FORFEITURE OF CONTRACT:

22.1 Contractor must forfeit all benefits of this Contract and County must retain all performance by Contractor and recover all consideration or the value of all consideration, paid to Contractor pursuant to this contract if:

22.1.1 Contractor was doing business at the time of submitting its proposal or had done business during the 365 day period immediately prior to the date of which its proposal was due with one or more Key Contracting Persons if Contractor has not disclosed the name of any such Key Contracting Person in its proposal which is expressly incorporated in this Contract; or

22.1.2 Contractor does business with a Key Contracting Person after the date on which the proposal that resulted in this Contract and prior to full performance of this Contract and fails to disclose the name of that Key Contracting Person in writing to each member of the Commissioners Court and to the County Clerk within ten (10) days commencing business with that Key Contracting Person.

23.0 NOTICES:

23.1 Any notice required or permitted to be given under this Contract by one party to the other shall be in writing and shall be given and deemed to have been given immediately if delivered in person to the address set

forth in this section for the party to whom the notice is given, or on the third day following mailing if placed in the United States Mail, postage prepaid, by registered or certified mail with return receipt requested, addressed to the party at the address set forth in this section.

23.2 The address of County for all purposes under this Contract is:

**Cyd Grimes, C.P.M., CPPO
Purchasing Agent
P.O. Box 1748
Austin, Texas 78767-1748**

23.3 The address of Contractor for all purposes under this contract and for all notices hereunder is the address shown in the Notice of Award.

23.4 Each party may change the address for notice to it by giving notice of the change in compliance with 23.01

24.0 **CONSTRUCTION OF CONTRACT:**

24.1 Law and Venue. This Contract is governed by the laws of the United States of America and Texas and all obligations under this Contract are performable in Travis County, Texas. Venue for any dispute arising out of this Contract will lie in the appropriate court of Travis County, Texas.

24.2 Severability. If any portion or portions of this Contract are ruled invalid, illegal, or unenforceable in any respect, by a court of competent jurisdiction, the remainder of it will remain valid and binding.

24.3 Headings. Headings and titles at the beginning of the various provisions of this Contract have been included only to make it easier to locate the subject matter covered by that part, section or subsection and are not to be used in construing this Contract.

24.4 Computation of Time. When any period of time is stated in this Contract, the time will be computed to exclude the first day and include the last day of period. If the last day of any period falls on a Saturday, Sunday, or a day that Travis County has declared a holiday for its employees, these days will be omitted from the computation. All hours stated in this Contract are stated in Central Standard Time from 2:00 o'clock a.m. on the first Sunday October until 2:00 o'clock a.m. on the first Sunday of April and in Central Daylight Saving Time from 2:00 o'clock a.m. on the first Sunday April until 2:00 o'clock a.m. on the first Sunday of October.

24.5 Gender and Number: Words of any gender in this Contract will be construed to include any other gender and words in either number will be construed to include the other unless the context in the Contract clearly requires otherwise.

25.0 ENTIRE CONTRACT:

All oral and written agreements between Contractor and County relating to the subject matter of this Contract that were made prior to the execution of this Contract have been reduced to writing and are contained in this Contract.

26.0 CONTRACTOR LIABILITY, INDEMNIFICATION AND CLAIMS NOTIFICATION:

Contractor shall indemnify County, its officers, agents, and employees, from and against any and all third party claims, losses, damages, causes of action, suits, and liability of every kind whether meritorious or not and, including all expenses of litigation, court costs, and reasonable attorney's fees, arising in connection with the services provided by Contractor under this Contract. It is the expressed intention of the parties to this Contract, both Contractor and County, that the indemnity provided for in this paragraph is indemnity by Contractor to indemnify and protect County from the consequences of Contractor's actions.

27.0 HUB PROCUREMENT PROGRAM:

27.1 Pursuant to the Travis County Historically Underutilized Business (HUB) Procurement Program, the Travis County Commissioners Court adopted goals for Certified HUB Subcontractor participation with an Overall 14.1% Minority-Owned Business Enterprise (MBE) goal and an Overall 15.0% Women-Owned Business Enterprise (WBE) goal (*Sub-goals: 2.5% African-American, 9.9% Hispanic, 1.7% Native/Asian-American*) to be observed by the County in its award of contracts and subcontracts to certified HUBs.

27.2 It is the policy of Travis County that HUBs shall have the maximum opportunity to participate in the performance of County contracts and subcontracts. Contractor shall make a "good faith effort" to take all necessary and reasonable steps to ensure HUBs maximum opportunity to participate as subcontractors. Failure by Contractor or subcontractor to carry out the County HUB Procurement Program shall constitute a breach of contract, and after notification of such breach by the Purchasing Agent may result in termination of this contract.

27.3 For purposes of HUB participation, Travis County will count the dollar amount of all firm fixed price/fixed quantity contracts, or the dollar amount of Purchase Orders placed against "Estimated" or "Not to Exceed" contracts.

27.4 The following section identifies the specific procedures to be followed with respect to this solicitation for proposals in compliance with the HUB Procurement Program.

27.5 **SECTION 1 - HUB PURCHASES**

27.5.1 To be eligible under this program, HUB Proposers and subcontractors must:

27.5.1.1 Be certified as HUB, M/WBE or DBE source by:

- (A) City of Austin Municipal Government,
- (B) Texas Unified Certification Program, or
- (C) State of Texas Building and Procurement Commission

27.5.1.2 Have on file in the Travis County Purchasing Office a proper Bidder's/Proposer's Application.

27.5.1.3 Identify the certifying agency and Item/Service for which is certified.

27.5.1.4 Obtain County approval of all proposed HUB subcontractors through the Purchasing Agent.

27.5.1.5 Complete the HUB Declaration form in the RFP package.

27.5.2 Any third party may challenge a firm's HUB status before or after certification. Such challenge must be in writing and submitted to the Purchasing Agent, including all relevant information available. If no merit to the challenge is found, the challenging party will be notified by the Purchasing Agent in writing and the matter will be considered closed. If merit is found, the firm in question will be notified by the Purchasing Agent of the challenge, who made it, and a summary of the allegations. The challenged firm will be required to submit, within a reasonable period of time, information in support of the firm's HUB status. The Purchasing Agent will make an evaluation and notify the parties of a proposed

determination, citing the basis for the decision, and providing an opportunity for an informal hearing to interested parties and affording an opportunity for a written or personal response. The Purchasing Agent will make a recommendation to the Commissioners Court for a final determination. The Purchasing Agent will inform all interested parties of the Commissioners Court's determination and its reasons. A firm's HUB status must remain accurately certified during the challenging procedure and may not be changed unless or until a successful challenge is finalized. (See also Par. 8.0, "CLARIFICATION OR OBJECTION TO PROPOSAL SPECIFICATIONS" in Part I, General Requirements, Section of the RFP.).

28.0 ADDITIONAL GENERAL PROVISIONS:

- 28.1 Contractor must comply with all federal and state laws and regulations, city and County ordinances, orders, and regulations, relating in any way to this Contract.
- 28.2 Contractor must secure all permits and licenses, pay all charges and fees, and give all notices necessary for lawful operations.
- 28.3 Contractor must pay all taxes and license fees imposed by the federal and the state governments and their agencies and political subdivisions upon the property and business of Contractor.
- 28.4 Despite anything to the contrary in this Contract, if Contractor is delinquent in payment of property taxes at the time of providing services, Contractor assigns the amount of Gross Receipts equal to the amount Contractor is delinquent in property tax payments to the Travis County Tax Assessor-Collector for the payment of the delinquent taxes.

29.0 DESIGNATED COUNTY HOLIDAYS 2012-2013: No services will be performed and deliveries will be accepted on designated holidays, unless specific prior arrangements have been made. Below is the approved holiday schedule. Future schedules are expected to be similar.

HOLIDAY	2012
Martin Luther King, Jr. Day	MondayJan16,.....2012
President's Day.....	MondayFeb.....20,.....2012
Memorial Day	MondayMay28,.....2012
Independence Day	WednesdayJul04,.....2012
Labor Day	MondaySep.....03,.....2012
Veteran's Day	MondayNov12,.....2012

Thanksgiving Day	Thursday	Nov.....22,.....2012
Friday after Thanksgiving	Friday	Nov.....23.....2012
Christmas Season	Monday	Dec25,.....2012
Christmas Season	Tuesday	Dec26,.....2012

30.0 MEDIATION:

When mediation is acceptable to both parties in resolving a dispute arising under this Agreement, the parties agree to use a mutually agreed upon mediator, or a person appointed by a court of competent jurisdiction, for mediation as described in Section 154.023 of the Texas Civil Practice and Remedies Code. Unless both parties are satisfied with the result of the mediation, the mediation will not constitute a final and binding resolution of the dispute. All communications within the scope of the mediation shall remain confidential as described in §154.073 of the Texas Civil Practice and Remedies Code, unless both parties agree, in writing, to waive the confidentiality.

31.0 TIN REQUIRED:

Contractor shall provide County with an Internal Revenue Form W-9, Request For Taxpayer Identification Number and Certification, that is completed in compliance with the Internal Revenue Code, its rule and regulations, and a statement of entity status in a form satisfactory to the County Auditor before any Contract funds are payable.

32.0 NON-WAIVER OF DEFAULT:

32.1 The waiver of a breach of any term or condition of this Contract is not a waiver of a subsequent breach of that term or condition, or a breach or subsequent breach of any other term of condition. No official, agent, employee, or representative of County may waive any breach of any term of condition of this Contract unless expressly granted that specific authority by Commissioners Court.

32.2 All rights of County under this Contract are specifically reserved and any payment, act or omission shall not impair or prejudice any remedy or right to County under it. Any right or remedy in this Contract shall not preclude the exercise of any other right or remedy under this Contract or under any law, nor shall any action taken in the exercise of any right or remedy be deemed a waiver of any other rights or remedies.

33.0 CERTIFICATION OF ELIGIBILITY:

This provision applies if the anticipated contract exceeds \$100,000. By submitting a proposal in response to the RFP solicitation, Contractor certifies that at the time of submission, Contractor was not on the federal government’s list of suspended, ineligible, or debarred contractors. If Contractor is placed on the list between the time of proposal submission and the time of execution of this Contract, Contractor shall notify the Travis County Purchasing Agent. Failure to do so may result in County termination of this Contract for default.

34.0 INSURANCE AND LIABILITY:

During the period of this Contract, Contractor shall maintain at his expense, insurance with limits not less than those prescribed below. With respect to required insurance, Contractor shall:

- (i) Name County as additional insured, as its interests may appear.
- (ii) Provide County a waiver of subrogation.
- (iii) Provide County with a thirty (30) calendar days advance written notice of cancellation or material change to said insurance.
- (iv) Provide the County Purchasing Agent at the address shown on Page 1 of this contract, a Certificate of Insurance evidencing required coverages within ten (10) calendar days after receipt of Notice of Award. **Also, please assure your certificate contains the contract number as indicated on the Contract Award form when issued by Travis County.**
- (v) Submit an original certificate of insurance reflecting coverage as follows:

Automobile Liability:

Bodily Injury (Each person)	\$250,000.00
Bodily Injury (Each accident)	\$500,000.00
Property Damage	\$100,000.00

General Liability (Including Contractual Liability):

Bodily Injury	\$500,000.00
Property Damage	\$100,000.00

Excess Liability:

Umbrella Form.....Not Required

Worker's Compensation:.....Statutory

35.0 SECURITY COMPLIANCE:

35.1 Network, Computer, and Information Security Compliance:

The goods and/or services solicited through RFP #120025-GM must be and remain in compliance with applicable Texas law.

The goods and/or services solicited through RFP #120025-GM must be and remain in compliance with all Travis County network, computer, software, and information security policies, standards, specifications, guidelines, processes and procedures already developed or deployed or subsequently developed or deployed and used by or for the Travis County Department of Information and Telecommunications Services ("ITS") and/or a department, office or division of any elected or appointed Travis County official (collectively, the "Travis County Security Requirements" or the "Security Requirements"). Contractor has executed a Travis County Non-Disclosure and Confidentiality Agreement and the documents comprising the Security Requirements have been obtained by Contractor.

35.2 Initial Compliance: Contractor's goods and/or services shall comply with the Security Requirements, including but not limited to the Travis County Asset Management Policy, Lifecycle Management Standard, Configuration Management Standard, Change Control Standard, and System Development Lifecycle Standard. Contractor's goods and/or services must operate with and be compatible with any and all network security, computer security, software security, and/or information security safeguards, including security hardware, software, appliances deployed by County (the "Security Safeguards").

35.3 Certification of Compliance: Contractor has performed a self-conducted compliance review of Contractor's goods and/or services and has provided to County, as part of its Proposal, written certification in the form of a completed, signed, and dated compliance review checklist, attesting that Contractor's goods and/or services are compliant with the Security Requirements. An authorized official of Contractor's company has signed and dated the compliance review checklist.

35.4 **Ongoing Compliance Upon Execution of Contract:**

Contractor's goods, services, practices, and/or procedures must remain in compliance with the Security Requirements and compatible with the Security Safeguards, including complying with any and all modifications and/or additions to the Security Requirements and/or Security Safeguards that may occur throughout the term of this Contract.

Contractor shall provide the required hardware, software, materials, expertise, and/or labor required to ensure ongoing compliance of the Contractor-provided goods and/or services with the Security Requirements, including operability and compatibility with the Security Safeguards as a part of ongoing maintenance and support.

The Contractor-provided goods, services, practices, and/or procedures must be accredited by the ITS Department Security Manager before being connected into the Travis County Government Network or placed into any County production operation environment. Accreditation is achieved by undergoing a Security Assessment that shows the Contractor supplied goods and/or services are compliant with the Security Requirements and Security Safeguards. This security evaluation of the specific solutions covered by this Contract may reveal aspects of the architecture, implementation, operation, maintenance, and/or other aspect of these solutions that may necessitate incorporating additional solution-specific information security requirements to protect County computers, networks, software, information, and facilities.

35.5 **Notification of Non-Compliance or Incompatibility:**

If Contractor determines, at any time during the Contract term, that Contractor's goods, services, practices, and procedures do not comply with County's current Security Requirements and/or are not compatible with County's current Security Safeguards, the Contractor shall notify the ITS Help Desk by no later than the end of the business day following the confirmation by the Contractor of the non-compliance or incompatibility.

If the County determines at any time during the Contract term that Contractor's goods, services, practices, and procedures do not comply with County's current Security Requirements and/or compatibility with County's current Security Safeguards, the County shall notify Contractor by no later than the end of the business day following the confirmation by Contractor of the non-compliance or incompatibility.

35.6 **Remedy of Non-Compliance or Incompatibility:**

In the event that either County or Contractor is notified of a non-compliance and/or incompatibility, Contractor shall:

- 1.) Determine the effort and cost to bring Contractor's goods, services, practices, and procedures into compliance and compatibility;
- 2.) Provide a draft working plan, including schedule, work effort and cost details, to remedy the non-compliance or incompatibility to County no later than 5 working days after notification of the non-compliance and/or the incompatibility to County has been confirmed.

County, at its sole discretion, shall determine whether Contractor must bring some, all, or none of the non-compliant or incompatible Contractor's goods, services, practices, and procedures into compliance with County's current Security Requirements and/or into compatibility with County's current Security Safeguards. Any instance of non-compliance or compatibility that the County does not require to be brought into compliance or compatibility will be noted as an exception. County may choose, in its sole discretion, at any time, to remove the exception and require compliance and/or compatibility.

Contractor shall be responsible for all costs associated with bringing Contractor-supplied goods, services and/or Contractor processes and practices into compliance with the Security Requirements and compatibility with the Security Safeguards.

County may, at its sole discretion, provide some, all or none of the hardware, software, materials, expertise, and labor that may be required from time to time to bring the Contractor-supplied goods, services, practices, and/or procedures into compliance with the Security Requirements and the Security Safeguards.

35.7 Connectivity and Access to County Network, Systems, Software, and/or Information:

Contractor and Contractor personnel who will be providing and/or maintaining goods and/or services, and who may from time to time access County systems, networks, software, and/or information, must be familiar with, and agree to adhere to and comply with the Security Requirements that pertain to and govern access to County computers, networks, software, and information including without limitation the Travis County Government Asset Protection Policy, Access Control Standard, Remote Access Standard, Security Awareness Policy, and Third Party Security Awareness Standard.

36.0 CONFLICT OF INTEREST QUESTIONNAIRE: If required by Chapter 176, Texas Local Government Code, Contractor shall complete and file a Conflict of

Interest Questionnaire with the County Clerk, Elections Division, 5501 Airport Blvd., Austin, Texas 78751. Contractor shall update this Questionnaire by September 1 of each year for the duration of this Contract, as required by Chapter 176 of the Local Government Code. In addition, if any statement on a submitted Questionnaire becomes incomplete or inaccurate, the Contractor shall submit an updated Questionnaire. Contractor should note that the law requires the County to provide access to a filed Questionnaire on the official Travis County Internet website.

Attachment D

**Knight Security Systems SecurePlan Administration Policy
Dated January, 2012**

Attachment E

Knight Security Systems Extended Equipment Warranty

Attachment F

Specific Requirements

Contractor shall provide the Systems and Services in strict compliance with the following Specific Requirements:

SCOPE OF SERVICE: Fixed-positioned cameras are recommended to video surveillance capability for all sides, entrances, and roof-top modes of entry at 700 Lavaca St and the 2nd level area of the associated garage parking facility. Cameras should be part of the existing exterior IP-based enterprise system and operate on a scaled system of installation on a per-camera (versus per controller) basis and become operative to an intelligent monitoring system.

Nineteen cameras should be positioned as specified on Attachments F-1 and F-2 (see below). All efforts for design, delivery & install, implementation, and subsequent maintenance shall be made towards fulfilling the requirements.

Attachment F-1 (the 700 Lavaca Camera Placement drawing) illustrates the desired locations for camera placement and the field of view for each. Thirteen locations are specified with two cameras at one location for a total of 15 cameras. Thirteen cameras will be fixed position and two will be PTZ .

Attachment F-2 (the Garage Camera Placement drawing) illustrates the desired locations for four fixed position cameras and the field of view for each. All cameras shall be internet protocol (IP)-driven cameras.

Contractor will provide ongoing maintenance and support post-implementation.

2.0 **TECHNICAL REQUIREMENTS:**

2.1 Camera Licensing for Video Management System (VMS): Each camera shall include a license key that is obtained through OnSSI (On-Net Surveillance Systems, Inc.) in order to connect to the county VMS. The license must be installed and configured to conform to the current video recording rate, recording location, schedule, and other general settings. All configuration must be done by an OnSSI-certified technician or engineer.

2.2 Building Exterior Cameras:

The preferred form factor for the fixed cameras shall be mini dome with weather resistant properties. The garage cameras will incorporate vandal resistant properties. The cameras shall be capable of HD or megapixel resolution with motion detection. Compression technology must include the option to use H.264, MPEG, and JPEG.

2.2.1 POWER

The preferred power source shall be power over Ethernet (POE).

2.2.2 DAY/NIGHT VIEWABILITY

All cameras shall have day/night capability. The main target (doors, glass walls, etc.) shall be viewable at all times during the day and within 80 feet when at night. The night/dim light feature for the PTZ will not be a consideration.

2.2.3 RESOLUTION

a) The resolution (HD or megapixel) must meet forensic review level quality.

NOTE: Primary targets can vary from 8' wide x 80' long to 40 degree tilt x 120 degree horizontal view. Travis County has available photographs taken from each assigned camera's vantage point. These are available to the Proposer in conjunction with the execution of the non-disclosure agreement.

b) The determination of the respective camera lens shall take into consideration the Horizontal Field of View (HFV) and the specific target under ideal conditions and lighting.

c) Pixels per square foot shall be between 50 and 80 PPS such that a clear image of a face is readily possible under forensic review.

2.2.4 NETWORK PROTOCOLS

The camera shall incorporate the use of SNMP (Simple Network Management Protocol) and any other protocol necessary for connection to the VMS.

2.2.5 DEVICE SECURITY

The camera must support a user-defined password that can be set at the camera and accepted by the VMS.

Attachment G

**Questions and Answers for Bid # P120025-GM – External Video Security
Cameras (History) Dated November 28, 2011**

Attachment H

STATE OF TEXAS}
COUNTY OF TRAVIS}

ETHICS AFFIDAVIT

Date: _____
Name of Affiant: _____
Title of Affiant: _____
Business Name of Contractor: _____
County of Contractor: _____

Affiant on oath swears that the following statements are true:

1. Affiant is authorized by Contractor to make this affidavit for Contractor.
2. Affiant is fully aware of the facts stated in this affidavit.
3. Affiant can read the English language.
4. Contractor has received the list of key contracting persons associated with this solicitation which is attached to this affidavit as Exhibit "A".
5. Affiant has personally read Exhibit "A" to this Affidavit.
6. Affiant has no knowledge of any Key Contracting Person on Exhibit "A" with whom Proposer is doing business or has done business during the 365 day period immediately before the date of this affidavit whose name is not disclosed in the solicitation.

Signature of Affiant

Address

SUBSCRIBED AND SWORN TO before me by _____ on _____,
2012.

Notary Public, State of _____

Typed or printed name of notary

My commission expires: _____

EXHIBIT A
LIST OF KEY CONTRACTING PERSONS

CURRENT

Position Held	Name of Individual Holding Office/Position	Name of Business Individual is Associated
County Judge	Samuel T. Biscoe	
County Judge (Spouse)	Donalyn Thompson-Biscoe	
Executive Assistant	Cheryl Brown	
Executive Assistant.....	Melissa Velasquez	
Executive Assistant.....	Josie Z. Zavala	
Executive Assistant.....	Cheryl Aker	
Commissioner, Precinct 1	Ron Davis	
Commissioner, Precinct 1 (Spouse).....	Annie Davis	Seton Hospital
Executive Assistant.....	Deone Wilhite	
Executive Assistant.....	Felicitas Chavez	
Commissioner, Precinct 2	Sarah Eckhardt	
Commissioner, Precinct 2 (Spouse).....	Kurt Sauer	Daffer McDaniel, LLP
Executive Assistant	Loretta Farb	
Executive Assistant	Joe Hon	
Executive Assistant	Peter Einhorn	
Commissioner, Precinct 3.....	Karen Huber	
Commissioner, Precinct 3 (Spouse).....	Leonard Huber	Retired
Executive Assistant.....	Garry Brown	
Executive Assistant.....	Jacob Cottingham	
Commissioner, Precinct 4.....	Margaret Gomez	
Executive Assistant.....	Edith Moreida	
Executive Assistant.....	Norma Guerra	
County Treasurer	Dolores Ortega-Carter	
County Auditor	Susan Spataro, CPA	
County Executive, Administrative.....	Vacant	
County Executive, Planning & Budget.....	Leslie Browder*	
County Executive, Emergency Services	Danny Hobby	
County Executive, Health/Human Services.....	Sherri E. Fleming	
County Executive, TNR	Steven M. Manilla, P.E.*	
County Executive, Justice & Public Safety	Roger Jefferies	
Director, Facilities Management	Roger El Khoury, M.S., P.E.	
Chief Information Officer.....	Joe Harlow	
Director, Records Mgmt & Communications	Steven Broberg	
Travis County Attorney	David Escamilla	
First Assistant County Attorney	Steve Capelle	
Executive Assistant, County Attorney.....	James Collins	
Director, Land Use Division.....	Tom Nuckols	
Attorney, Land Use Division	Julie Joe	
Attorney, Land Use Division	Christopher Gilmore	
Director, Transactions Division	John Hille	
Attorney, Transactions Division	Daniel Bradford	
Attorney, Transactions Division	Mary Etta Gerhardt	
Attorney, Transactions Division	Barbara Wilson	
Attorney, Transactions Division	Jim Connolly	
Attorney, Transactions Division	Tenley Aldredge	
Director, Health Services Division	Vacant	

Attorney, Health Services Division Prema Gregerson
 Purchasing Agent Cyd Grimes, C.P.M., CPPO
 Assistant Purchasing Agent Marvin Brice, CPPB
 Assistant Purchasing Agent Bonnie Floyd, CPPO, CPPB, CTPM
 Purchasing Agent Assistant IV Vacant
 Purchasing Agent Assistant IV Lee Perry
 Purchasing Agent Assistant IV Jason Walker
 Purchasing Agent Assistant IV Richard Villareal
 Purchasing Agent Assistant IV Patrick Strittmatter*
 Purchasing Agent Assistant IV Lori Clyde, CPPO, CPPB
 Purchasing Agent Assistant IV Scott Wilson, CPPB
 Purchasing Agent Assistant IV Jorge Talavera, CPPO, CPPB
 Purchasing Agent Assistant IV George R. Monnat, C.P.M., A.P.P.
 Purchasing Agent Assistant IV John E. Pena, CTPM
 Purchasing Agent Assistant IV Rosalinda Garcia
 Purchasing Agent Assistant III Shannon Pleasant, CTPM*
 Purchasing Agent Assistant III David Walch
 Purchasing Agent Assistant III Michael Long, CPPB
 Purchasing Agent Assistant III Loren Breland, CPPB
 Purchasing Agent Assistant III Nancy Barchus, CPPB
 Purchasing Agent Assistant III Jesse Herrera, CTP, CTPM, CTCM*
 Purchasing Agent Assistant III C.W. Bruner, CTP
 Purchasing Agent Assistant II Jayne Rybak, CTP*
 HUB Coordinator Sylvia Lopez
 HUB Specialist Betty Chapa
 HUB Specialist Jerome Guerrero
 Purchasing Business Analyst Scott Worthington
 Purchasing Business Analyst Jennifer Francis
 Manager, Network & Systems Operations Services... Walter LaGrone
 Project Manager III, Information Technology Svcs... David Lampl
 Business Analyst II, Information Technology Svcs... Frank Esparza
 Architectural Associate Senior, Facilities Mgt Kim Nguyen
 Building Maintenance Div Mgr, Facilities Mgt Lloyd Evans

FORMER EMPLOYEES

<u>Position Held</u>	<u>Name of Individual</u> <u>Holding Office/Position</u>	<u>Date of Expiration</u>
Purchasing Agent Assistant IV.....	Oralia Jones, CPPB.....	07/31/12
County Executive, Planning & Budget.....	Rodney Rhoades	08/19/12
Purchasing Agent Assistant IV.....	Diana Gonzalez..	12/16/12
Director, Health Services Division	Beth Devery	03/09/13
Purchasing Agent Assistant III.....	Elizabeth Corey, C.P.M.	03/14/13
Attorney, Transactions Division.....	Tamara Armstrong	03/30/13
Executive Assistant	Lori Duarte	06/15/13

* - Identifies employees who have been in that position less than a year.

Contractor acknowledges that Contractor is doing business or has done business during the 365 day period immediately prior to the date on which Contractor is executing this Contract with the following key contracting persons and warrants that these are the only such key contracting persons:

If no one is listed above, Contractor warrants that Contractor is not doing business and has not done business during the 365 day period immediately prior to the date on which Contractor is executing this Contract with any key contracting person.

Attachment I

**Non-Disclosure and Confidentiality Agreement for
Documents Comprising the ITS Security Requirements**



ATTACHMENT A - BEST AND FINAL OFFER

Customer System Agreement

Proposal #: 5986

Date: May 3, 2012

Prepared for

Frank Esparza
Travis County-1
700 Lavaca
Austin, TX 78767

Phone: (512) 854-5226

Prepared by

Bob Minchew
Knight Security Systems, LLC
5321 Industrial Oaks Blvd., Ste. 111
Austin, TX 78735
Phone: 512-892-8801
Fax: 512-891-0283

Scope of Work

RFP# P120025-GM External Video Security Cameras

Scope of Work

Knight Security will provide and install 19 cameras, at the 700 Lavaca St Building, in accordance with RFP# P120025-GM, to record on the existing Travis County ONSSI video management system. Scope of work includes:

Note: Items in bold italics represent changes to scope from original proposal per Travis County "Best and Final" instructions dated 3/21/2012.

Head End Equipment:

- 19 ONSSI camera licenses with one year of software upgrades and support.

Cameras:

- **13 Sony DH160 720p HD infrared mini-dome fixed position cameras covering the outside perimeter of the 700 Lavaca building.**
- Four Sony DH180 720p HD infrared mini-dome fixed position cameras covering the Commissioner parking area in the parking garage.
- One Sony RS86N 36x PTZ camera mounted on the northwest corner of the mechanical penthouse located on the 15th story roof.
- **One Sony RS86N 36x PTZ at camera position #13 (replaces originally proposed fixed position).**

Execution:

- Install plenum rated Cat6A cabling from each camera location to the nearest IDF within 300'.
- **Provide and install LAN/PoE extenders for four garage cameras due to distance over 300'.**
- Provide EMT conduit and blocks from the 2nd floor roof penetrations to nine camera locations. Cameras will be mounted with custom fabricated non-penetrating parapet mounts to avoid damage to the recently refurbished roof.
- Provide EMT conduit from the parking garage IDF to four camera locations.
- **Extend EMT conduit from parking garage to main building lower level IDF.**
- **Provide and install 24 port Cisco WS-C2960-24PC-S switch in main building lower level IDF.**
- **Provide and install rack mount 1000VA UPS in main building lower level IDF.**
- Mount, aim and focus 19 network cameras.
- Configure and enroll 19 cameras on the owner provided ONSSI video management server.

System Design, Project Management and Training:

- Submit shop drawings, equipment schedule, manufacturer's literature and project implementation plan.
- Knight Security project manager attendance of one project kick-off meeting, up to two weekly progress meetings, and a final system commissioning and acceptance.
- Knight Security project manager will create a master project schedule, manage changes, and provide associated services during the project.
- Submit record documents including as-built drawings and final configuration schedules.
- Provide up to three hours of end user training upon final system acceptance.



Customer System Agreement

Proposal #: 5986

Date: May 3, 2012

Prepared for

Frank Esparza
Travis County-1
700 Lavaca
Austin, TX 78767

Phone: (512) 854-5226

Prepared by

Bob Minchew
Knight Security Systems, LLC
5321 Industrial Oaks Blvd., Ste. 111
Austin, TX 78735
Phone: 512-892-8801
Fax: 512-891-0283

Conditions and Qualifications:

- Work provided by Knight Security is during normal business hours. Additional costs will be incurred if non-standard hours work is required.
- Customer to provide free and clear access to site.
- All network infrastructure, excluding cabling and patch cords, is to be provided by the customer and is supported with UPS systems in accordance with Travis County policy.
- Video recording server, patch panels, network PoE switches (except tunnel IDF), other components not referenced in the RFP are to be provided by the owner (except Tunnel IDF).
- Customer IT to provide IP scheme and configure VLAN to interface with the video surveillance system.
- Cabling distances are estimated at the maximum 100m Ethernet distance. Additional costs will apply if Ethernet extension devices are required.
- Existing roof penetrations will support the new camera infrastructure. Should a new penetration be required, additional costs will apply.

The quantities of materials noted above Scope of Work are intended to be descriptive. Should there be any discrepancy between the Scope of Work narrative and the device quantities shown in the Equipment section of this proposal, the specific device quantities in the Equipment section shall supersede those that may be stated in the narrative.

Project Progress Invoicing:	
System Engineering, Project Plan, Mobilization	14,350.00
Equipment Delivered to Site	40,597.22
Equipment and Cabling Installed	14,350.00
Final Acceptance	5182.00

Equipment

<i>Item Description</i>	<i>Item Nbr</i>	<i>Qty</i>	<i>Price/Unit</i>	<i>Ext. Price</i>
CCTV AC WALL MOUNT PWR.SUPP.; 4 FUSED OUTPUTSCULUS LISTED	ALTV244175UL	2.00	\$133.80	\$267.60
NETWORK HD VANDAL MINIDOME W/ IR DUAL STREAM JPEG/MPEG4 H264	SNC-DH180	4.00	\$1,345.96	\$5,383.84
OUTDOOR SD 36X	SNC-RS86N	2.00	\$3,463.46	\$6,926.92
ROOF(PARAPET) MOUNT BRACKET WHITE,	UNI-RMB1	1.00	\$400.40	\$400.40
HD 720P HD 1.3 MEGAPIXLE VANDA IR IP66 HEATER D/N POE	SNC-DH160	13.00	\$883.96	\$11,491.48
PENDANT MOUNT ADAPTER WITH WALL MOUNT	UNI-MDB3	14.00	\$125.13	\$1,751.82
NetDVMS Camera Licenses:	DVMS-1C	19.00	\$228.65	\$4,344.35
18-2C STR PLENUM	4040PL	0.50	\$131.22	\$65.61
Custom Fabricated Nonpenetrating Parapet Mount	KSS-Fabrication	9.00	\$357.14	\$3,214.26
Conduit and Boxes	Conduit and Boxes	1.00	\$2,380.00	\$2,380.00
23-4P UNS SOL PVC C6 Blu Jkt	775609-S	7.00	\$253.09	\$1,771.63
Snagless Molded Boot Cat6 Patc Cable, Green, 5ft	UTP-6700-05G	38.00	\$7.19	\$273.26
Gooseneck wall mount bracket white finish, use with UNI-ON	UNI-WMB1	1.00	\$130.00	\$130.00



Customer System Agreement

Proposal #: 5986

Date: May 3, 2012

Prepared for

Frank Esparza
 Travis County-1
 700 Lavaca
 Austin, TX 78767

Phone: (512) 854-5226

Prepared by

Bob Minchew
 Knight Security Systems, LLC
 5321 Industrial Oaks Blvd., Ste. 111
 Austin, TX 78735
 Phone: 512-892-8801
 Fax: 512-891-0283

1000VA UPS System SmartPro Rack/Shelf/Tower Digital LCD Line-Interactive 120V 8 Outlets	SMART1000LCD	1.00	\$177.80	\$177.80
OUTREACH Max POE-powered LAN & POE extender	VOR-ORM	4.00	\$168.00	\$672.00
Cisco Catalyst 2960 24 10/100 PoE + 2 T/SFP LAN Lite Image	WS-C2960-24PC-S	1.00	\$1,346.25	\$1,346.25

Equipment Total \$40,597.22

Services

<i>Service Description</i>	<i>Ext. Price</i>
Commercial Install - Rental Equipment	\$1,200.00
Comm Inst - Cabling - Labor	\$15,300.00
Commercial Install Devices - Labor	\$5,100.00
Comm Inst - Project Engineering	\$2,280.00
Comm Inst - Project Management	\$3,800.00
Comm Inst - Lead install / System Configuratio	\$1,020.00
MSRV-SecurePlan	\$5,182.00

Services Total \$33,882.00

Other Charges

Travel: \$0.00

Freight: \$0.00

Misc: \$0.00

Approved by: _____

Approval date: _____

Subtotal: \$74,479.22
 Discount: \$0.00
 Sales Tax: \$0.00

**Please review Scope of Work closely. All verbal representations disclaimed.
 System quote valid for 60 Days. Terms of Master System Agreement apply.**

Total: \$74,479.22

ATTACHMENT B: CONTRACTOR'S PROPOSAL

KNIGHT
SECURITY SYSTEMS
HONOR, INTEGRITY, SERVICE



Company Information

Transmittal Page

Detailed Proposal

Attachment A

References

Required Documents

Product Specifications

KNIGHT
SECURITY SYSTEMS
HONOR. INTEGRITY. SERVICE



Date: 11-30-2011

Mr. Cyd V. Grimes
Purchasing Agent
700 Lavaca Suite 800
Austin, Texas 78701

Proposal For: RFP #P120025-GM

Dear Mr. Grimes,

I would personally like to thank you for the opportunity to propose solutions for your facility. We understand that you have a choice when it comes to your security needs and we value the fact that you chose Knight Security Systems to bid your project. I ask that you consider each part of the design carefully. We will assist you and your staff in all aspects and make revisions as required. We look forward to working with you on this project and enjoying a long and mutually beneficial relationship with your organization.

Please be assured that Knight Security Systems will provide a system that is unmatched by all others and one that will provide years of reliable service and quality. We have reviewed the RFP carefully and put together a proposal that suits the requirements of the RFP, while taking into consideration cost consciousness and the unique needs of the County. If there is any further information that I can provide, please do not hesitate to contact me on my direct line at 512-892-8801, or by email, BMinchew@KnightSecurity.com.

Best Regards,

Bob Minchew
Director Business Development
Knight Security Systems, LLC

Proven Security Solutions You Can Trust

Knight Security Systems

Phil Lake
President

Martin Krohn
Vice President, South Texas

H.B. 'Trey' West
Vice President, North Texas

Chris Hugman, P.E.
Vice President, Central Texas

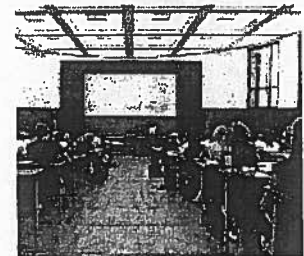
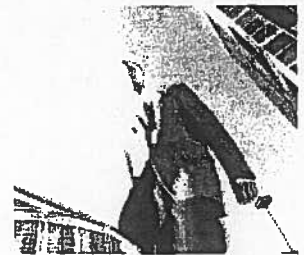

*Fire & Life Safety
Intrusion
Point Monitoring*



*Access Control
Video Surveillance
Intercom*

Knight Security Systems

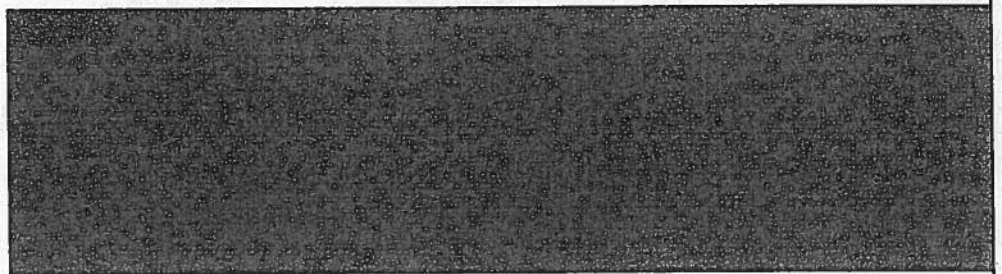
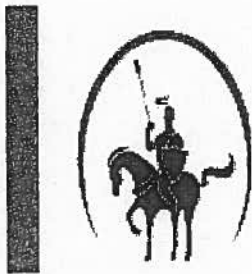

Company Overview
Management Team
Customers
Technology Partners

*Fire & Life Safety
Intrusion
Point Monitoring*

KNIGHT
SECURITY SYSTEMS
HONOR. INTEGRITY. SERVICE.



*Access Control
Video Surveillance
Intercom*



Knight Security Systems

Knight Security Systems, designs, installs and services advanced security solutions Access Control, Video Surveillance, Intrusion, Encrypted Wireless Networks, Fire & Life safety systems for clients state wide. Full service locations in Austin, Dallas and Houston. Our professional team designs your unique technology solution.

Knight Security Systems began in 1983 and has more than 3,500 systems installed in the United States

Our core values sets Knight apart.

- **HONOR**
Personal standards maintained without legal or other obligation
- **INTEGRITY**
Strict personal honesty and independence
- **SERVICE**
To meet a need with goods, services and labor for another

Business Security:	Industrial Security:	Financial Security:	Government Security:	Education Security:	Residential Security:
<ul style="list-style-type: none"> • Video Surveillance • Access Control • Intrusion Alarm • Fire Detection • Monitoring • Duress Alarm • False Alarms 	<ul style="list-style-type: none"> • Multi-Mesh • Video Surveillance • Access Control • Intrusion Alarm • Fire Detection • Monitoring 	<ul style="list-style-type: none"> • Operational • Video Surveillance • Access Control • Hold Up • Intrusion • Fire Detection • Monitoring • Duress 	<ul style="list-style-type: none"> • Video Surveillance • Access Control • Intrusion Alarm • Fire Detection • Monitoring • Duress Alarm • False Alarms 	<ul style="list-style-type: none"> • Video Surveillance • Access Control • Intrusion Alarm • Fire Detection • Monitoring • Duress Alarm • False Alarms 	<ul style="list-style-type: none"> • Home Alarms • Home Fire Alarms • Outdoor Protection • Personal Emergency

Dallas/Fort Worth Office:
10105 Technology Blvd West
Suite 100
Dallas, TX 75220
214-350-1632

Austin Office:
5321 Industrial Oaks Blvd.,
Suite 111
Austin TX 78735,
512-892-8801

Houston Office:
25275 Budde Road,
Suite 17
Spring, TX 77380
281-681-3473

Security License: B-03566
Fire License: ACR-2825



Fire & Life Safety
Intrusion
Point Monitoring



Access Control
Video Surveillance
Intercom



Government Security Systems

Local, County, State and Federal governmental entities represent the very heart of our communities. With increasingly hostile threats, effective security measuring are increasingly important to protect facilities and prevent interruption to government operations and all levels. Whether the local courthouse or state law enforcement, all government entities are subject to random criminal acts and must take appropriate security precautions to deter and mitigate dangerous situations and maintain the public trust.



Because of our extensive experience with enterprise level network based systems for a variety the government entities Knight Security brings current technology and a broad perspective to insure the right solution for any situation. Video Surveillance, Access Control and Intrusion Detection systems all have an important role to play in the overall security of a facility. Effective security strategy considers how each of these technologies is employed at a given location. With custom design services, a wide variety of available technologies and turn key installation services all available via government procurement contracts, Knight Security is a trusted partner for all levels of government entities throughout Texas.

Knight Security Systems is one of the only companies on the DIR with a contract offering both video surveillance and access control security solutions.

Safe Sight merged with Knight Security Systems this year to become one of the largest and most experienced providers of security solutions in Texas providing:

- **Video surveillance** (including analog and digital IP systems)
- **Access control** (both stand alone and integrated systems)
- **Intrusion Detection**
- **Fire Detection**
- **Alarm Monitoring**

Knight Security has a long and proven history supporting the public sector including federal, state and local government, hospitals, school districts and higher education. As a manufacturer certified dealer, our solutions are designed and installed by licensed Texas security experts with offices across the State.

We also offer custom design services and turnkey installation services – all available via GoDirect.

Go **Direct**





Recognized Value from Knight Security Turnkey Solutions

- ▶ Intrusion Alarm
- ▶ Access Control
- ▶ Video Surveillance
- ▶ Fire & Life Safety
- ▶ Encrypted Wireless
- ▶ Communications

- Needs Assessment
- Code Compliant System Design
- Fire Permits & Submittals
- Consultation
- Product Selection
- System Installation
- System Configuration
- As built Drawings
- Training
- Parts & Labor Warranty
- Post Installation Service
- SecurePlan
- Monitoring

- ▶ Design
- ▶ Installation
- ▶ Service

Knight Security Systems takes responsibility and provides the in house resources to support the entire process required for a "Turnkey Solution"

There is no need to call the product supplier or the subcontracted installation company or the third party service organization



Management Team

Phil Lake, President

Phil Lake has been in the Life Safety / Security, and Controls industries for 30 years. In his most recent position, Phil has taken the Fire Safety Division of Siemens Building Technologies from a debilitating loss in 2001 to a substantial and sustainable profit. This role included manufacturing & product development, 42 field offices providing systems installation and service. Prior to Siemens, Phil has turned around and grown businesses at Chubb Security Canada and Chubb, USA. Honeywell Canada Limited allowed Phil to move into operational management. His career spanned thirteen years at Honeywell starting as Controller of a \$60 million Division and moving through ever increasing operational management positions. Phil earned a Certified General Accountant Degree (CPA equivalent), in Toronto and studied Industrial Marketing in the Executive Programs of the University of Toronto.



Martin Krohn, Vice President South Texas

Martin Krohn has 23 years experience in the Fire Detection and Alarm Industry. He has held and been active in every position in the fire and security alarm industry; including field sales, installation, and service of alarm systems. Martin has previously owned his own company in partnership with Trey West for seven years and held positions of Sales Manager for Chubb Security; General Manager, District Manager, and Regional Director for Siemens Building Technologies. Martin is trained as a Six Sigma Process Improvement Black Belt and has run many process improvement initiatives for Siemens Building Technologies. Martin holds a BS degree in Industrial Technology from Texas A&M University.



H.B. 'Trey' West, Vice President North Texas

Trey West has extensive experience as a senior manager and entrepreneur in the Electronic Building Systems industry. Trey most recently was the VP Operations for Siemens Security Systems, where he led the effort to build Siemens' World Class Monitoring Center in the DFW area. He has held the position of Regional Director for Siemens Fire Safety's Southern Region, as well as a General Manager for Chubb Security's North Texas operation. Trey, partnering with Martin Krohn, has previous entrepreneurial experience with Makrowest, Inc. a start-up fire and security business; which sold to Chubb Security in 1989. Trey holds an Electrical Engineering degree from the University of Texas.



Chris Hugman, P.E. Vice President Central Texas

Chris Hugman brings over 20 years of experience as a corporate executive in both the telecommunications and the security industries. In 2003, Hugman founded the security integration company Safe Sight in Austin TX focusing on the convergence of traditional security technology with the next generation network based systems. Hugman grew Safe Sight into a multi-million dollar company with a prestigious customer list in both the private and public sectors. In April 2009, Safe Sight merged with Knight Security Systems to take advantage of the natural synergies between the two companies.



Hugman has previously served in executive positions with Security Broadband, ConnectSouth, WorldCom, Brooks Fiber Communications, and SBC/AT&T. Additionally, Chris has been among the founding leadership of venture backed start-up companies, and has architected and deployed \$100's of millions in technology infrastructure to serve thousands of clients. Chris holds a Bachelor of Science in Electrical Engineering and an MBA from Southern Methodist University in Dallas, and is a licensed Professional Engineer.



Team Qualifications

- Security License B-03566
- Fire License ACR-2825
- Technical staff with and an average of 10 years of Intrusion Alarm, Video systems, Access Control, and Fire & Life safety experience.
- Management team with an average of 20 years of Security Industry business management.
- Dedicated 24 x 7 technical support
- On Site 24 x 7 Dedicated Service
- Locations in Dallas • Ft. Worth • Houston • Austin



*Fire & Life Safety
Intrusion
Point Monitoring*



*Access Control
Video Surveillance
Intercom*



SecurePlan: Exclusive Service Level Agreement

In security there are no second chances. A crisis is no time to discover there is something wrong with your system. This is why it's critical to your businesses' security to have *SecurePlan* from Knight Security Systems. *SecurePlan* provides an exclusive program designed to match your growing security needs and ensure maximum operation in a cost and time effective manner. In fact, *SecurePlan* surpasses and is superior to any warranty because it keeps you one step ahead of your overall security needs. This approach will help you to identify and address changes in your security needs and/or risks before they become an issue. Achievement of this goal is based on eight critical reasons:

- **Priority Dispatch with GUARANTEED Same Day Service**

Only *SecurePlan* customers receive PRIORITY DISPATCH SERVICE if the service call is placed before noon on a regular business day. When we receive your call, we'll immediately dispatch an experienced Knight Service Technician to your business. If you've requested a service call before noon on a regular business day and a Knight Service Technician fails to service your system the same day, you'll receive a FREE month of *SecurePlan*.

- **Labor and travel cost during normal business hours is included.**

This means from 8:00am to 5:00pm the labor cost of repairs and replacement is included in the *SecurePlan* package. This reduces your cost and allows you to budget for a fixed amount. No untimely or surprise expenses.

- **SecurePlan provides a 25% discount on labor rates**

Because service issues don't run on your schedule, what happens if your system needs service after hours? This usually results in costly repair costs. However, as a *SecurePlan* customer, you will have the advantage of a 25% discount on emergency overtime service and system expansion additions.

- **Device repair or replacement**

SecurePlan covers normal wear and tear. So, there is no need to worry about the cost of an expensive DVR or Pan tilt zoom camera replacement. *SecurePlan* has it covered. Acts of god and misuse will however, be charged extra.

- **System software upgrades and license fees**

Are you getting the latest versions of software? What are the fees? What about manufacturer support and technical updates? *SecurePlan* includes all of these! No need to worry about latest versions or the programmer cost of upgrades, Knight's *SecurePlan* does it for you!

- **Annual Functional Tests**

It is important to keep your security system operating at peak performance. As a *SecurePlan* customer, you'll receive annual visits to your business by one of our trained professionals to review the system and test its overall function and operation. If repairs are required, Knight Security Systems will provide, at no additional charge, repairs to the system and the equipment. We'll even test the batteries and if they require replacement, we'll replace them for FREE! However, *SecurePlan* repairs exclude acts of God, vandalism, tampering, or services performed by persons other than Knight Security personnel.

- **FREE Loaner Equipment**

If your system malfunctions or fails, it may need to be repaired by the manufacturer. It is not uncommon for manufacturer repairs to take several weeks, or even a month. Time you just can't afford to be without your security system. Here is yet another example of why *SecurePlan* is superior to a warranty! While the equipment is off to get repaired, your system is up and running with Knight's loaner equipment. Because There Are No Second Chances!

- **No Surprise Expenses**

How do you eliminate the surprise of costly service expenses? Only *SecurePlan* eliminates varying or additional costly expenses when you least expect them. How? By taking advantage of Knight's exclusive PRIORITY DISPATCH with Guaranteed Same Day Service (if a service call is placed by noon), Annual Functional Tests, and FREE Loaner Equipment. These all work together to protect you and your budget from the unexpected. *SecurePlan* provides its customers with much more than a "simple warranty". It provides customers with a plan that exceeds and is superior to warranty!



Customers

Select List of Customers

Client Case Studies

*Fire & Life Safety
Intrusion
Point Monitoring*

KNIGHT
SECURITY SYSTEMS
HONOR. INTEGRITY. SERVICE.



*Access Control
Video Surveillance
Intercom*



Customers

Select Customers

- Central Texas Medical Center
- Smithville Regional Hospital
- Dell Children's Medical Center of Central Tx.
- Lakeside Hospital
- Northwest Hill Surgical Hospital
- Cornerstone Hospital
- Samuels Jewelers
- Whole Foods
- Sprouts Farmers Markets
- American Bank
- American Bank of Texas
- Clearview Data Management
- Tom Thumb
- Safeway
- Fiesta Foods
- Dallas Country Club
- La Plaza Mall (McAllen TX)
- Prien Lake Mall
- Ingram Park Mall
- Texas Lottery Commission
- Texas Dept of Criminal Justice
- Texas Parks and Wildlife
- Travis County
- City of Houston
- City of Brenham
- WCAD Appraisal District
- Georgetown ISD
- Belton ISD
- Texas Lutheran University
- Paul Quinn College
- North Central Texas COG
- North Central Texas Workforce
- Dell Jewish Center
- Grace Covenant Church
- First Baptist Georgetown

Government



Healthcare



Education

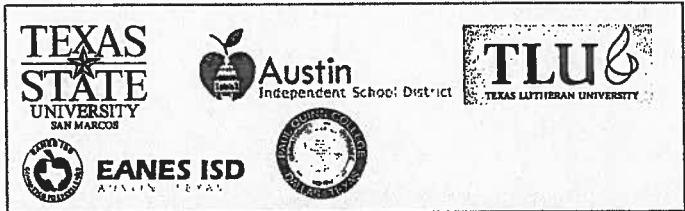

Private Sector



Fire & Life Safety
Intrusion
Point Monitoring



Access Control
Video Surveillance
Intercom



Client Case Studies – Healthcare

CTMC
CENTRAL TEXAS
MEDICAL CENTER

Campus Wide Network Security & Surveillance System

- Integrated S2 and ONSSI
- 50+ Network Cameras
- 50+ Access Controlled Doors & Point Monitoring
- Hugs Infant protection Integration
- Fire alarm Integration
- Interactive Mapping
- Emergency Lock Down
- On-site and Remote Service & Technical Support

CHG Cornerstone
HEALTHCARE GROUP

Building Wide Network Security & Surveillance System

- S2 Access Control
- Networked - i3DVR Video system – Perimeter and covert Cameras
- Entry Communication system w/remote release
- Integration with Access Control
- Emergency Lock Down
- On-site and Remote Service & Technical Support

 **Smithville Regional Hospital**
A caring partner of the Smithville Hospital Authority

Perimeter Access control & Communication System

- S2 -Building perimeter & Interior Access Control
- KinderGuard Infant protection Integration
- Emergency Lock Down
- On-site and Remote Service & Technical Support

HEALTHSOUTH

**NORTHWEST HILLS
SURGICAL HOSPITAL**

Perimeter Access control & Communication System

- S2-Building Access Control
- ONSSI-Video Surveillance System
- Audio/Video Entry communication system
- Integrated Wireless Panic
- Emergency Lock Down
- On-site and Remote Service & Technical Support





Client Case Studies – Education



Multi-Campus Network Surveillance System

- Main Campus + 3 remote Campuses
- 100+ Network Cameras
- Centralized Servers with failover architecture
- Wireless Network Links
- Completed 4Q2008
- On-site and Remote Maintenance & Support



District Wide Network Video System

- Certified Network Cabling
- Installed by Safe Sight
 - 35 Schools
 - 500+ Cameras
- Turnkey Install
- As-Built Drawings



District Wide Network Surveillance System

- 13 Campus Locations
- 300+ Network Cameras
- 78 Access Control Centralized Servers
- Wireless | Doors + 6 Gates
- Links
- Integration with Access Control
- Interactive Mapping
- Lock Down Capabilities
- On-site and Remote Service & Technical Support





Client Case Studies – Government



CLE – Crime Labs

- Crime Labs selected Knight Security (Safe Sight) a DIR integrator that could secure facilities statewide
- Designed each location to fit required needs.
- Six months of stored video for drug vaults.
- Wireless infrastructure as needed Secured 13 facilities with ONSSI NetDVR (upgradeable and scalable)
- Installed on time and within budget
- System allows DPS to check video 7x24 from any location in the world.



Texas Health and Human Services Commission

IP video securing

- Currently updating and adding new security statewide via DIR contract
- Region 8 installed IP video securing 14 facilities.
- Region 7 needed one vendor to integrate intrusion, access control and IP Video.
- Central control of all facilities at one or multiple locations
- Unlock/lock capabilities from anywhere on the network
- Provides instant add or delete of access
- Provides complete lockdown of facilities
- Badge Access disarms building or partitions.
- Integrates all security for central control



Technology Partners



DIR Vendors (Video)



Other Video Vendors



Access Control Vendors



Alarm Vendors



Fire & Life Safety
Intrusion
Point Monitoring



Access Control
Video Surveillance
Intercom



Responsibility Matrix

The Knight Security Responsibility Matrix reflects all of the essential activities conducted in the course of project execution by all parties involved in project.

Project Responsibilities

Task	Knight Team	Travis County
Organize and Conduct Initial Program Kickoff Meeting	P	
Development of System Design, Project Plan & Schedule of Values	P	
Development of Master Project Plan & Schedule	P	
Approval of System Design, Project Plan & Schedule of Values		P
Approval of Master Project Plan & Schedule		P
Conduct Project Meetings	P	
Develop & Maintain detailed drawings & Equipment Schedules	P	
Provide Written Communications regarding work site conditions, restrictions and limitations for each campus		P
Maintain updated Master Project Plan	P	
Financial Management, Material Procurement, Project Invoicing	P	
Timely Processing, Approval, and Payment of KSS Invoices		P
Coordinate In-Progress Reviews for active sites	P	
Coordinate & Facilitate Change Management Process	P	
Materials and Equipment Pre-installation configuration & staging	P	
Assemble and deliver final Close Out / As-Built documents	P	
Designate Primary Point for Travis County		P

Site Level Responsibilities

Task	Knight Team	Travis County
Host Initial Site Orientation Meeting		P
Pre-Install Walkthrough & Design Verification	P	
Network Materials Ordered		P
Network Crews Mobilized to Site		P
Network Materials Rec'd on Site and Tagged		P
Travis County Acceptance & Asset Tag of Materials Received		P
Pre-Construction Utility Assessment	P	
Network Construction		P
Clear identified work areas		P
Provide support to preventing interruptions and delays in work activity		P
Network Equipment Start up, Configuration and Testing	P	
Network Cable Drops in Place & Tested	P	
Addition of electrical outlet to available circuits as required	P	
Cameras and Equipment Ordered	P	
Camera Install Crew Mobilized	P	
Cameras & Equipment Rec'd onsite	P	
Servers Installed & Configured		P
Cameras Installed	P	
Cameras Enrolled on Servers	P	
System Configured & Tested	P	
Camera Installation Acceptance		P
Camera View Acceptance		P
Client Workstation in Place		P
Client Workstations (2) Configured	P	
System Acceptance & Turn-over		P
As Built Documentation Complete	P	
On-site User and Administrator Training	P	
*Primary (P)		



Knight Security Systems' Quality Approach

"Quality is never an accident; it is always the result of high intention, sincere effort, intelligent direction and skillful execution; it represents the wise choice of many alternatives."

- William A. Foster

Quality Planning

The above quote from William A. Foster underlines the importance of intentional planning for Quality from the very beginning - in the planning process. Knight Security has long recognized that thoughtful planning is fundamentally the single most important element to insure ultimate success in any undertaking, project or process no matter what the size or scale.

This Knight Security design team for Barksdale AFB is led by a Professional Engineer with over 25 years of network design and deployment experience. With the Barksdale AFB Mission and Vision in mind, Knight Security has worked intensively to pre-engineer and plan virtually every aspect of this project. The Knight Security video surveillance solution to Barksdale is based upon these fundamental concepts to insure a quality system:

1. Careful technology selection to minimize the variety of system elements and platforms to be deployed. In fact, Knight Security's design uses only 3 different system elements across the entire platform.
2. Development of three common equipment configurations to be used across all sites.
3. Planned Pre-staged configuration of equipment in a controlled environment.

These three key elements will streamline and simplify all aspects of the project, dramatically improving the likelihood of a timely and successful project implementation. This approach with standardized equipment, project management and installation practices will reduce or eliminate the potential for change, oversight and surprise.

Dallas Office: 10105 Technology Blvd West, Suite 100, Dallas, TX 75220, 214-350-1632

Houston Office: 25275 Budde Road, Suite 17, Spring, TX 77380, 281-681-3473

Austin Office: 5321 Industrial Oaks Blvd., Suite 111, Austin TX 78735, 512-892-8801

www.KnightSecurity.com

Security License B-03566 Fire Contractor License ACR-2825

Proven Security Solutions You Can Trust



This standardization, intentional system design along with world class technology partners provides a Quality Approach that is second to none. Not only do these practices lead to the highest quality deployment, but will also allow us to accelerate our schedule well ahead of the project deadline stated in the project RFO. The Knight Security video solution is "Ready to Deploy."

Quality Assurance

With a detailed system plan and a well defined and systematic process, our experienced technical personnel and on-site project management overseeing the implementation are well equipped to deliver the superior quality expected by Barksdale AFB.

While overseeing the activities in each dorms, the project manager will communicate job progress, identify and eliminate potential obstacles, and make certain Barksdale AFB expectations are exceeded.

Project Manager Role and Responsibilities:

- Creates and executes project work plans and revises as appropriate to meet changing needs and requirements.
- Identifies resources needed and assigns individual responsibilities.
- Manages day-to-day operational aspects of a project and scope.
- Reviews deliverables prepared by team before passing to client.
- Effectively applies our methodology and enforces project standards.
- Prepares for engagement reviews and quality assurance procedures.
- Minimizes our exposure and risk on project.
- Ensures project documents are complete, current, and stored appropriately.
- Facilitates team and client meetings effectively.
- Holds regular status meetings with project team.
- Keeps project team well informed of changes within the organization and general corporate news.
- Effectively communicates relevant project information to superiors.
- Delivers engaging, informative, well-organized presentations.
- Resolves and/or escalates issues in a timely fashion.
- Understands how to communicate difficult/sensitive information tactfully.

Additionally, Knight Security and our project and technology partners are standing behind our crews in the field to provide technical support and guidance to meet our common objective.

Dallas Office: 10105 Technology Blvd West, Suite 100, Dallas, TX 75220, 214- 350 1632

Houston Office: 25275 Budde Road, Suite 17, Spring, TX 77380, 281- 681-3473

Austin Office: 5321 Industrial Oaks Blvd., Suite 111, Austin TX 78735, 512-892-8801

www.KnightSecurity.com

Security License B-03566 Fire Contractor License ACR-2825

Proven Security Solutions You Can Trust



Quality Control

Knight Security will achieve a high degree of Quality Control chiefly as a result of our "intelligent direction and skillful execution" as asserted in the earlier Foster quotation. The practical elements of this Quality Control include:

1. Conducting work in a controlled and supervised environment during the assembly and pre-staging process.
2. Communication of and adherence to long standing Standard Operating Procedures and Industry Practices.
3. Standardized system elements and pre-assembled configurations reduces or eliminates need for installation personnel to improvise and configure components "on the fly".
4. On site inspection of work progress and quality.
5. Weekly Status Updates and Progress Reports.
6. On Site inspection of Work Progress.
7. Intermediate milestone inspections.
8. Acceptance Procedures and Milestones internal to the Knight Security Project Team.
9. Extensive Final System Test Procedures prior to Customer Acceptance to confirm intended system functionality.
10. Long term Quality Control is insured by the SNMP based Network Management Application that monitors all the status of all system elements.
11. Documentation and photographs of final system as-built conditions and configurations.
12. Final System Acceptance and Sign-off.

Knight Security is prepared and ready to deliver the proposal Video Surveillance solution based upon the proven methods described herein. While Knight Security's has made every possible effort to maintain a price competitive offering, our primary objective was to delivering the highest quality option available to Barksdale AFB for this important project. Knight Security is prepared to begin system deployment in the very near term.

Dallas Office: 10105 Technology Blvd West, Suite 100, Dallas, TX 75220, 214-350-1632
Houston Office: 25275 Budde Road, Suite 17, Spring, TX 77380, 281-681-3473
Austin Office: 5321 Industrial Oaks Blvd., Suite 111, Austin TX 78735, 512-892-8801



Customer System Agreement

Proposal #: 5078

Date: November 30, 2011

Prepared for

George Monnat
Travis County - 700 Lavaca
700 Lavaca St
Austin, TX 78701

Phone:

Prepared by

Bob Minchew
Knight Security Systems, LLC
5321 Industrial Oaks Blvd., Ste. 111
Austin, TX 78735
Phone: 512-892-8801
Fax: 512-891-0283

Scope of Work

RFP# P120025-GM
External Video Security Cameras

Scope of Work

Knight Security will provide and install 19 cameras, at the 700 Lavaca St Building, in accordance with RFP# P120025-GM, to record on the existing Travis County ONSSI video management system. Scope of work includes:

Head End Equipment:

- 19 ONSSI camera licenses with one year of software upgrades and support.

Cameras:

- 14 Sony DH160 720p HD infrared mini-dome fixed position cameras covering the outside perimeter of the 700 Lavaca building.
- Four Sony DH180 720p HD infrared mini-dome fixed position cameras covering the Commissioner parking area in the parking garage.
- One Sony RS86N 36x PTZ camera mounted on the northwest corner of the mechanical penthouse located on the 15th story roof.

Execution:

- Install plenum rated Cat6A cabling from each camera location to the nearest IDF within 300'.
- Provide EMT conduit and blocks from the 2nd floor roof penetrations to nine camera locations. Cameras will be mounted with custom fabricated non-penetrating parapet mounts to avoid damage to the recently refurbished roof.
- Provide EMT conduit from the parking garage IDF to four camera locations.
- Mount, aim and focus 19 network cameras.
- Configure and enroll 19 cameras on the owner provided ONSSI video management server.

System Design, Project Management and Training:

- Submit shop drawings, equipment schedule, manufacturer's literature and project implementation plan.
- Knight Security project manager attendance of one project kick-off meeting, up to two weekly progress meetings, and a final system commissioning and acceptance.
- Knight Security project manager will create a master project schedule, manage changes, and provide associated services during the project.
- Submit record documents including as-built drawings and final configuration schedules.
- Provide up to three hours of end user training upon final system acceptance.

Conditions and Qualifications:

- Work provided by Knight Security is assumed to be during normal business hours. Additional costs may be incurred if non-standard hours work is required.
- Customer to provide free and clear access to site.
- All network infrastructure, excluding cabling and patch cords, is to be provided by the customer and is supported with UPS systems in accordance with Travis County policy.
- Video recording server, patch panels, network PoE switches, UPS and other components not referenced in the RFP are to be provided by the owner.

REFERENCES VERIFICATION REPORT
(must be submitted with proposal)

1.0 The References Verification Report is to be completed by Proposers submitting a proposal and is a required part of the proposal package. Please respond to all fields listed on the form. Additional pages may be added if more space is required. At the County's discretion, an incomplete form may be justification for rejection of a proposal. The information provided may be verified prior to award.

1.1 Company Name: _____ Texas Health and Human Services Commission
Dept of Aging and Disability Services

Address: 701 West 51st

City/State/Zip: Austin, Texas 78751

Phone: 512-438-4537 Email: Cendra.Simmons@dads.state.tx.us

Contact Person: Cendra Simmons _____

Title: Project Manager

Description of Service/Application/Platform: _____

Knight Security was awarded the \$12 million dollar contract to design, provide, and install more than 3,200 high definition video cameras in 335 buildings at twelve state-supported living centers across Texas. The solution included over 30 miles of fiber optic cable and a full network infrastructure build out to support the ONSSI Video Surveillance system. __

Location of Service: Statewide project

Date of Service: 10-1-2010 – 2-15-2011

1.2 Company Name: Eanes ISD _____

Address: 601 Camp Craft Street _____

City/State/Zip: Austin, Texas 78746

Phone: 512-732-9045 Email: LReddin@eanesisd.net

Contact Person: Les Reddin _____

Title: Director of Maintenance and Operations
REFERENCES VERIFICATION REPORT continued
(must be submitted with proposal)

Description of Service/Application/Platform: _____

In conjunction with a major bond initiative, Eanes ISD (Austin area), included a district wide security system upgrade covering the district's thirteen campuses. Knight Security provided a turnkey and fully integrated Video Surveillance (ONSSI) and Access Control (S2) solution for the district including over 300 cameras and 82 access control doors.

Location of Service: Austin Texas

Date of Service: 4-1-2009 – 11-30-2009

1.3 Company Name: Texas State Capitol

Address: 1400 Congress Ave

City/State/Zip: Austin, Texas 78701

Phone: 512-424-7526 Email: gil.glastetter@txdps.state.tx.us

Contact Person: Gil Glastetter

Title: Project Manager

Description of Service/Application/Platform: _____

Knight Security was chosen as integrator of choice to provide and install security upgrades including Video Surveillance (ONSSI) and Access Control (S2) for the State Capitol. The project solution included conversion of American Dynamics to ONSSI, 178 megapixel cameras, conversion of CCure to S2 for 130 doors and database conversion of 25,000 users during session

Location of Service: State Capitol

Date of Service: 8-30-2010 – 2-4-2011



Contact	Solution Provided
<p>Eanes ISD Les Reddin Director of Maintenance and Operations 601 Camp Craft Rd. Austin, Texas 78746 512-732-9045 LReddin@eanesisd.net</p>	<p>In conjunction with a major bond initiative, Eanes ISD (Austin area), included a district wide security system upgrade covering the district's thirteen campuses. Knight Security provided a turnkey and fully integrated Video Surveillance (ONSSI) and Access Control (S2) solution for the district including over 300 cameras and 82 access control doors.</p>
<p>Texas Health and Human Services Commission Dept of Aging and Disability Services Cendra Simmons Project Manager 701 West 51st Austin, TX 78751 Cendra.Simmons@dads.state.tx.us</p>	<p>Knight Security was awarded the \$12 million dollar contract to design, provide, and install more than 3,200 high definition video cameras in 335 buildings at twelve state-supported living centers across Texas. The solution included over 30 miles of fiber optic cable and a full network infrastructure build out to support the ONSSI Video Surveillance system.</p>
<p>Texas State Capitol Gil Glastetter Project Manager 512-424-7526 5805 North Lamar Boulevard Austin, TX 78752 gil.glastetter@txdps.state.tx.us</p>	<p>Knight Security was chosen as integrator of choice to provide and install security upgrades including Video Surveillance (ONSSI) and Access Control (S2) for the State Capitol. The project solution included conversion of American Dynamics to ONSSI, 178 megapixel cameras, conversion of CCure to S2 for 130 doors and database conversion of 25,000 users during session</p>
<p>Department of Public Safety Drivers License Bureau Terry Helton Project Manager 512-424-2399 5805 North Lamar Boulevard Austin, TX 78752 Terry.Helton@txdps.state.tx.us</p>	<p>DPS Drivers License Bureau chose Knight Security to upgrade surveillance to ONSSI at their DL offices throughout the state. The systems are controlled locally and reports back to headquarters in Austin.</p>
<p>Department of Public Safety Crime Labs Pat Johnson Director 512-424-2143 5805 North Lamar Boulevard Austin, TX 78752 Pat.Johnson@dps.texas.gov</p>	<p>DPS Crime Labs needed an integrator that was consistent with installation and product for their new Crime Labs in Texas. They chose Knight Security to install a fully integrated system with ONSSI, S2 and DMP.</p>

STATE OF TEXAS}
COUNTY OF TRAVIS}

ETHICS AFFIDAVIT

Date: November 23, 2011
Name of Affiant: Phil Lake
Title of Affiant: President
Business Name of Proposer: Knight Security Systems
County of Proposer: Travis

Affiant on oath swears that the following statements are true:

- 1. Affiant is authorized by Proposer to make this affidavit for Proposer.
2. Affiant is fully aware of the facts stated in this affidavit.
3. Affiant can read the English language.
4. Proposer has received the list of Key Contracting Persons associated with this solicitation which is attached to this affidavit as Exhibit "A".
5. Affiant has personally read Exhibit "A" to this Affidavit.

Affiant has no knowledge of any Key Contracting Person on Exhibit "A" with whom Proposer is doing business or has done business during the 365 day period immediately before the date of this affidavit whose name is not disclosed in the solicitation.

Signature of Affiant (handwritten signature)

5321 Industrial Oaks Blvd Suite 111 Austin, Texas 78735
Address

SUBSCRIBED AND SWORN TO before me by on NOV 23, 2011.

Notary Public, State of Texas (handwritten signature)

Whitney Oldfather
Typed or printed name of notary

My commission expires: 8.16.2014

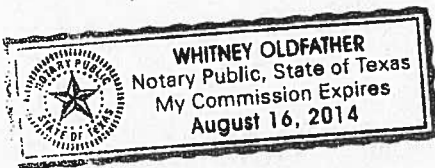

EXHIBIT A
LIST OF KEY CONTRACTING PERSONS
November 4, 2011

CURRENT

<u>Position Held</u>	<u>Name of Individual Holding Office/Position</u>	<u>Name of Business Individual is Associated</u>
County Judge	Samuel T. Biscoe	
County Judge (Spouse)	Donalyn Thompson-Biscoe	
Executive Assistant	Cheryl Brown	
Executive Assistant	Melissa Velasquez	
Executive Assistant	Josie Z. Zavala	
Executive Assistant	Cheryl Aker	
Commissioner, Precinct 1	Ron Davis	
Commissioner, Precinct 1 (Spouse)	Annie Davis	Seton Hospital
Executive Assistant	Deone Wilhite	
Executive Assistant	Felicitas Chavez	
Commissioner, Precinct 2	Sarah Eckhardt	
Commissioner, Precinct 2 (Spouse)	Kurt Sauer	Daffer McDaniel, LLP
Executive Assistant	Loretta Farb	
Executive Assistant	Joe Hon	
Executive Assistant	Peter Einhorn	
Commissioner, Precinct 3	Karen Huber	
Commissioner, Precinct 3 (Spouse)	Leonard Huber	Retired
Executive Assistant	Garry Brown	
Executive Assistant	Lori Duarte	
Executive Assistant	Jacob Cottingham*	
Commissioner, Precinct 4	Margaret Gomez	
Executive Assistant	Edith Moreida	
Executive Assistant	Norma Guerra	
County Treasurer	Dolores Ortega-Carter	
County Auditor	Susan Spataro, CPA	
County Executive, Administrative	Vacant	
County Executive, Planning & Budget	Vacant	
County Executive, Emergency Services	Danny Hobby	
County Executive, Health/Human Services	Sherri E. Fleming	
County Executive, TNR	Steven M. Manilla, P.E.*	
County Executive, Justice & Public Safety	Roger Jefferies	
Director, Facilities Management	Roger El Khoury, M.S., P.E.	
Chief Information Officer	Joe Harlow	
Director, Records Mgmt & Communications	Steven Broberg	
Travis County Attorney	David Escamilla	
First Assistant County Attorney	Steve Capelle	
Executive Assistant, County Attorney	James Collins	
Director, Land Use Division	Tom Nuckols	
Attorney, Land Use Division	Julie Joe	
Attorney, Land Use Division	Christopher Gilmore	
Director, Transactions Division	John Hille	
Attorney, Transactions Division	Tamara Armstrong	
Attorney, Transactions Division	Daniel Bradford	
Attorney, Transactions Division	Mary Etta Gerhardt	
Attorney, Transactions Division	Barbara Wilson	
Attorney, Transactions Division	Jim Connolly	

Attorney, Transactions Division Tenley Aldredge
 Director, Health Services Division Beth Devery
 Attorney, Health Services Division Prema Gregerson
 Purchasing Agent Cyd Grimes, C.P.M.
 Assistant Purchasing Agent Marvin Brice, CPPB
 Assistant Purchasing Agent Bonnie Floyd, CPPO, CPPB, CTPM
 Purchasing Agent Assistant IV Diana Gonzalez
 Purchasing Agent Assistant IV Lee Perry
 Purchasing Agent Assistant IV Jason Walker
 Purchasing Agent Assistant IV Richard Villareal
 Purchasing Agent Assistant IV Patrick Strittmantter*
 Purchasing Agent Assistant IV Lori Clyde, CPPO, CPPB
 Purchasing Agent Assistant IV Scott Wilson, CPPB
 Purchasing Agent Assistant IV Jorge Talavera, CPPO, CPPB
 Purchasing Agent Assistant IV George R. Monnat, C.P.M., A.P.P.
 Purchasing Agent Assistant IV John E. Pena, CTPM
 Purchasing Agent Assistant III Shannon Pleasant*
 Purchasing Agent Assistant III David Walch
 Purchasing Agent Assistant III Michael Long, CPPB
 Purchasing Agent Assistant III Elizabeth Corey, C.P.M.
 Purchasing Agent Assistant III Rosalinda Garcia
 Purchasing Agent Assistant III Loren Breland, CPPB
 Purchasing Agent Assistant II C.W. Bruner, CTP
 Purchasing Agent Assistant III Nancy Barchus, CPPB
 HUB Coordinator Sylvia Lopez
 HUB Specialist Betty Chapa
 HUB Specialist Jerome Guerrero
 Purchasing Business Analyst Scott Worthington
 Purchasing Business Analyst Jennifer Francis
 Manager, Network & Systems Operations Services... Walter LaGrone
 Project Manager III, Information Technology Svcs... David Lampl
 Business Analyst II, Information Technology Svcs... Frank Esparza

FORMER EMPLOYEES

<u>Position Held</u>	<u>Expiration</u>	<u>Name of Individual</u>	<u>Holding Office/Position</u>	<u>Date of</u>
County Executive, TNR.....		Joseph Gieselman		01/31/12
Purchasing Agent Assistant IV		Oralia Jones, CPPB		07/31/12
County Executive, Planning & Budget.....		Rodney Rhoades		08/19/12

* - Identifies employees who have been in that position less than a year.

Proposer acknowledges that Proposer is doing business or has done business during the 365 day period immediately prior to the date on which this proposal is due with the following Key Contracting Persons and warrants that these are the only such Key Contracting Persons:

None _____

If no one is listed above, Proposer warrants that Proposer is not doing business and has not done business during the 365 day period immediately prior to the date on which this proposal is due with any Key Contracting Person.

ATTACHMENT B

Non-Disclosure and Confidentiality Agreement for Documents Comprising the ITS Security Requirements

Instructions: After signing this document, please return to George Monnat via Fax at 512-854-9185 or via email at george.monnat@co.travis.tx.us. Upon receipt of the signed document, the requested information will be forwarded. The original signed NDA should be returned with vendor's RFP response.

1. In the interest of obtaining all information relevant for purposes of providing the requested goods and/or services in connection with RFP #P120025-GM, Security Control System (the "RFP"), the undersigned¹ hereby agrees, to the extent permitted by law, to treat confidential any and all information furnished to the undersigned, but in any event the information contained in the specific documents listed below (the "Confidential Information").

The undersigned agrees to treat the Confidential Information as confidential during their review of the RFP and any associated documents; during formulation and delivery of a formal response to the RFP; and during any other associated tasks or functions related to this phase of the Travis County procurement process (including negotiations of any modifications, amendments, addenda or extensions of or to the RFP) and in perpetuity thereafter.

2. The undersigned acknowledges that Travis County has developed the Confidential Information and that Travis County considers such information confidential and proprietary. The undersigned shall not, without first obtaining County's prior written consent, disclose the Confidential Information to any person or entity other than to the employees, counsel and accountants of the undersigned or duplicate the Confidential Information in whole or in part.
3. The sole purposes for which the undersigned may disclose the Confidential Information to its officers, employees and agents shall be limited to: (i) the evaluation of a continuing and/or further business relationship with Travis County; and (ii) in the event the RFP and/or subsequent Contract is modified, amended, or extended, the fulfillment of its contractual obligations to Travis County.
4. The undersigned shall maintain the confidentiality of the Confidential Information, including instructing its officers, employees and agents regarding the obligations of the undersigned under this Non-Disclosure and Confidentiality Agreement and to take all other reasonable precautions to prevent disclosure of the Confidential Information.

¹ As used in this Non-Disclosure and Confidentiality Agreement, the term "the undersigned" includes the officers, employees and agents of the vendor receiving the documents listed herein.

5. The undersigned acknowledges and understands that the documents listed below will change over time to accommodate the needs of Travis County. Travis County reserves the right to revise (by way of modification, deletion or supplementation) the documents and the Confidential Information contained therein and, following such revision, agrees to provide the updated version of any revised document to the undersigned as soon as practicable. The undersigned agrees that this Non-Disclosure and Confidentiality Agreement shall apply to current and future versions of the documents listed below.
6. In the event the undersigned chooses not to respond to the RFP, or is not the successful proposer, the undersigned agrees to destroy all copies of the Confidential Information immediately.
7. By furnishing the Confidential Information to the undersigned pursuant to this Non-Disclosure and Confidentiality Agreement, Travis County does not waive or otherwise relinquish any right of non-disclosure or other privilege available to it under the Texas Public Information Act or other applicable statute, law or regulation.

By: Bob Minchew

Title: Director Business Development

Company Name: Knight Security Systems

Date: November 23, 2011

Email address: BMinchew@KnightSecurity.com

**Documents Currently Comprising the Travis County
Information Security Policies and Standards**

Ref #	Document Title
G00	Information Security Program Charter
P01	Asset Identification & Classification Policy
P01.S01	Information Classification Standard
P01.S02	Information Labeling Standard
P02	Asset Protection Policy
P02.S01	Access Control Standard
P02.S02	Remote Access Standard
P02.S02.01	Remote Access Standard For Third Parties
P02.S03	Encryption Standard
P02.S04	Physical Access Standard
P02.S05	Availability Protection Standard

P02.S06	Integrity Protection Standard
P02.S07	Malware Protection Standard
P02.S08	Information Handling Standard
P02.S09	Auditing and Log Management Standard
P02.S10	Intrusion Protection Standard
P02.TS01	Asset Protection Technical Standard for AS/400 (OS/400)
P02.TS02	Asset Protection Technical Standard for UNIX Servers
P02.TS03.04	Asset Protection Technical Standard for Novell eDirectory
P02.TS04.04	Asset Protection Technical Standard for Windows Server 2003 and 2008
P02.TS04.05	Asset Protection Technical Standard for Active Directory 2008
P02.TS04.10	Asset Protection Technical Standard for Embedded Windows
P02.TS05.09	Asset Protection Technical Standard for Internet Application Hosting
P03	Asset Management Policy
P03.S01	Life Cycle Management Standard
P03.S02	Configuration Management Standard
P03.S03	Change Control Standard
P03.S04	System Development Lifecycle Standard
P04	Acceptable Use Policy
P04.S01	Internet Acceptable Use Standard
P04.S02	Electronic Mail Acceptable Use Standard
P07	Information Security Awareness Policy
P07.S04	Third Party Information Security Awareness Standard

ACORD

CERTIFICATE OF LIABILITY INSURANCE

DATE (MM/DD/YYYY)

09/29/2011

THIS CERTIFICATE IS ISSUED AS A MATTER OF INFORMATION ONLY AND CONFERS NO RIGHTS UPON THE CERTIFICATE HOLDER. THIS CERTIFICATE DOES NOT AFFIRMATIVELY OR NEGATIVELY AMEND, EXTEND OR ALTER THE COVERAGE AFFORDED BY THE POLICIES BELOW. THIS CERTIFICATE OF INSURANCE DOES NOT CONSTITUTE A CONTRACT BETWEEN THE ISSUING INSURER(S), AUTHORIZED REPRESENTATIVE OR PRODUCER, AND THE CERTIFICATE HOLDER.

IMPORTANT: If the certificate holder is an ADDITIONAL INSURED, the policy(ies) must be endorsed. If SUBROGATION IS WAIVED, subject to the terms and conditions of the policy, certain policies may require an endorsement. A statement on this certificate does not confer rights to the certificate holder in lieu of such endorsement(s).

PRODUCER Roberts & Crow, Inc. 12221 Merit Drive Suite 300 Dallas, TX 75251	CONTACT NAME: Jolene Honeycutt	
	PHONE (A/C, No, Ext): (972)770-4499	FAX (A/C, No): (972)770-4451
E-MAIL ADDRESS:		
INSURER(S) AFFORDING COVERAGE		NAIC #
INSURER A: First Mercury Insurance Co.	10657	
INSURER B: Utica National Ins Co. of TX	43478	
INSURER C:		
INSURER D:		
INSURER E:		
INSURER F:		

INSURED
 Knight Security Systems, LLC
 10105 Technology Boulevard West, Ste 100
 Dallas, TX 75220

COVERAGES **CERTIFICATE NUMBER: 10-11 Casualty** **REVISION NUMBER:**

THIS IS TO CERTIFY THAT THE POLICIES OF INSURANCE LISTED BELOW HAVE BEEN ISSUED TO THE INSURED NAMED ABOVE FOR THE POLICY PERIOD INDICATED. NOTWITHSTANDING ANY REQUIREMENT, TERM OR CONDITION OF ANY CONTRACT OR OTHER DOCUMENT WITH RESPECT TO WHICH THIS CERTIFICATE MAY BE ISSUED OR MAY PERTAIN, THE INSURANCE AFFORDED BY THE POLICIES DESCRIBED HEREIN IS SUBJECT TO ALL THE TERMS, EXCLUSIONS AND CONDITIONS OF SUCH POLICIES. LIMITS SHOWN MAY HAVE BEEN REDUCED BY PAID CLAIMS.

INSR LTR	TYPE OF INSURANCE	ADDL SUBR INSR WVD	POLICY NUMBER	POLICY EFF (MM/DD/YYYY)	POLICY EXP (MM/DD/YYYY)	LIMITS
A	GENERAL LIABILITY		FMM1024091	12/01/2010	12/01/2011	EACH OCCURRENCE \$ 1,000,000
	<input checked="" type="checkbox"/> COMMERCIAL GENERAL LIABILITY					DAMAGE TO RENTED PREMISES (Ea occurrence) \$ 100,000
	<input type="checkbox"/> CLAIMS-MADE <input checked="" type="checkbox"/> OCCUR					MED EXP (Any one person) \$ 10,000
	GEN'L AGGREGATE LIMIT APPLIES PER: <input type="checkbox"/> POLICY <input checked="" type="checkbox"/> PROJECT <input type="checkbox"/> LOC					PERSONAL & ADV INJURY \$ 1,000,000 GENERAL AGGREGATE \$ 3,000,000 PRODUCTS - COMPIOP AGG \$ 3,000,000
B	AUTOMOBILE LIABILITY		BAP3241911	12/01/2010	12/01/2011	COMBINED SINGLE LIMIT (Ea accident) \$ 1,000,000
	<input checked="" type="checkbox"/> ANY AUTO					BODILY INJURY (Per person) \$
	<input type="checkbox"/> ALL OWNED AUTOS					BODILY INJURY (Per accident) \$
	<input type="checkbox"/> HIRED AUTOS					PROPERTY DAMAGE (Per accident) \$
A	<input checked="" type="checkbox"/> UMBRELLA LIAB <input checked="" type="checkbox"/> OCCUR		CUM1001103	12/01/2010	12/01/2011	EACH OCCURRENCE \$ 2,000,000
	<input type="checkbox"/> EXCESS LIAB <input type="checkbox"/> CLAIMS-MADE					AGGREGATE \$ 2,000,000
	DED <input checked="" type="checkbox"/> RETENTION \$ 10,000					\$
	WORKERS COMPENSATION AND EMPLOYERS' LIABILITY					WC STATUTORY LIMITS OTHER
	ANY PROPRIETOR/PARTNER/EXECUTIVE OFFICER/MEMBER EXCLUDED? (Mandatory in NH)	N/A				E.L. EACH ACCIDENT \$
	If yes, describe under DESCRIPTION OF OPERATIONS below					E.L. DISEASE - EA EMPLOYEE \$
						E.L. DISEASE - POLICY LIMIT \$

DESCRIPTION OF OPERATIONS / LOCATIONS / VEHICLES (Attach ACORD 101, Additional Remarks Schedule, if more space is required)

Certificate holder is named as additional insured as required by written contract.

CERTIFICATE HOLDER

CANCELLATION

	SHOULD ANY OF THE ABOVE DESCRIBED POLICIES BE CANCELLED BEFORE THE EXPIRATION DATE THEREOF, NOTICE WILL BE DELIVERED IN ACCORDANCE WITH THE POLICY PROVISIONS.
	AUTHORIZED REPRESENTATIVE <i>Barry Crow</i> Barry Crow/JKCSR

© 1988-2010 ACORD CORPORATION. All rights reserved.



CERTIFICATE OF LIABILITY INSURANCE

DATE (MM/DD/YYYY)
09/29/2011

THIS CERTIFICATE IS ISSUED AS A MATTER OF INFORMATION ONLY AND CONFERS NO RIGHTS UPON THE CERTIFICATE HOLDER. THIS CERTIFICATE DOES NOT AFFIRMATIVELY OR NEGATIVELY AMEND, EXTEND OR ALTER THE COVERAGE AFFORDED BY THE POLICIES BELOW. THIS CERTIFICATE OF INSURANCE DOES NOT CONSTITUTE A CONTRACT BETWEEN THE ISSUING INSURER(S), AUTHORIZED REPRESENTATIVE OR PRODUCER, AND THE CERTIFICATE HOLDER.

IMPORTANT: If the certificate holder is an ADDITIONAL INSURED, the policy(ies) must be endorsed. If SUBROGATION IS WAIVED, subject to the terms and conditions of the policy, certain policies may require an endorsement. A statement on this certificate does not confer rights to the certificate holder in lieu of such endorsement(s).

PRODUCER Doug Jones c/o AJG Risk Management Services, Inc. 8800 E. Chaparral Rd, Suite 230 Scottsdale, AZ 85250	CONTACT NAME: PHONE (A/C, No, Ext): (480) 951-4177 FAX (A/C, No): (480) 951-4266	
	E-MAIL ADDRESS:	
INSURED Oasis Acqulsition, Inc Alt. Emp: KNIGHT SECURITY SYSTEMS, LLC 2054 Vista Parkway Suite 300 West Palm Beach, FL 33411	INSURER(S) AFFORDING COVERAGE	
	INSURER A : Zurich-American Insurance Company NAIC # 16535	
	INSURER B :	
	INSURER C :	
	INSURER D :	
	INSURER E :	

COVERAGES **CERTIFICATE NUMBER:** 11FL075788971 **REVISION NUMBER:**

THIS IS TO CERTIFY THAT THE POLICIES OF INSURANCE LISTED BELOW HAVE BEEN ISSUED TO THE INSURED NAMED ABOVE FOR THE POLICY PERIOD INDICATED. NOTWITHSTANDING ANY REQUIREMENT, TERM OR CONDITION OF ANY CONTRACT OR OTHER DOCUMENT WITH RESPECT TO WHICH THIS CERTIFICATE MAY BE ISSUED OR MAY PERTAIN, THE INSURANCE AFFORDED BY THE POLICIES DESCRIBED HEREIN IS SUBJECT TO ALL THE TERMS, EXCLUSIONS AND CONDITIONS OF SUCH POLICIES. LIMITS SHOWN MAY HAVE BEEN REDUCED BY PAID CLAIMS.

INSR LTR	TYPE OF INSURANCE	ADDL INSR	SUBR WVD	POLICY NUMBER	POLICY EFF (MM/DD/YYYY)	POLICY EXP (MM/DD/YYYY)	LIMITS
	GENERAL LIABILITY <input type="checkbox"/> COMMERCIAL GENERAL LIABILITY <input type="checkbox"/> CLAIMS-MADE <input type="checkbox"/> OCCUR GEN'L AGGREGATE LIMIT APPLIES PER: <input type="checkbox"/> POLICY <input type="checkbox"/> PRO-JECT <input type="checkbox"/> LOC						EACH OCCURRENCE \$ DAMAGE TO RENTED PREMISES (Ea occurrence) \$ MED EXP (Any one person) \$ PERSONAL & ADV INJURY \$ GENERAL AGGREGATE \$ PRODUCTS - COM/OP AGG \$ \$
	AUTOMOBILE LIABILITY <input type="checkbox"/> ANY AUTO <input type="checkbox"/> ALL OWNED AUTOS <input type="checkbox"/> SCHEDULED AUTOS <input type="checkbox"/> HIRED AUTOS <input type="checkbox"/> NON-OWNED AUTOS						COMBINED SINGLE LIMIT (Ea accident) \$ BODILY INJURY (Per person) \$ BODILY INJURY (Per accident) \$ PROPERTY DAMAGE (Per accident) \$ \$
	<input type="checkbox"/> UMBRELLA LIAB <input type="checkbox"/> OCCUR <input type="checkbox"/> EXCESS LIAB <input type="checkbox"/> CLAIMS-MADE <input type="checkbox"/> DED <input type="checkbox"/> RETENTION \$						EACH OCCURRENCE \$ AGGREGATE \$ \$
A	WORKERS COMPENSATION AND EMPLOYERS' LIABILITY <input type="checkbox"/> ANY PROPRIETOR/PARTNER/EXECUTIVE OFFICER/MEMBER EXCLUDED? (Mandatory in NH) If yes, describe under DESCRIPTION OF OPERATIONS below			WC 29-38-687-09	06/01/2011	06/01/2012	<input checked="" type="checkbox"/> WC STATUTORY LIMITS <input type="checkbox"/> OTHER E.L. EACH ACCIDENT \$ 1,000,000 E.L. DISEASE - EA EMPLOYEE \$ 1,000,000 E.L. DISEASE - POLICY LIMIT \$ 1,000,000
				Location Coverage Period:	06/01/2011	06/01/2012	Client# 6693-1

DESCRIPTION OF OPERATIONS / LOCATIONS / VEHICLES (Attach ACORD 101, Additional Remarks Schedule, if more space is required)

Coverage is provided for only those employees leased to but not subcontractors of:

KNIGHT SECURITY SYSTEMS, LLC
 10105 TECHNOLOGY BLVD W STE 100
 DALLAS, TX 75220

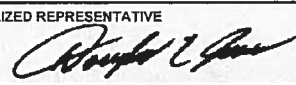
CERTIFICATE HOLDER	CANCELLATION SHOULD ANY OF THE ABOVE DESCRIBED POLICIES BE CANCELLED BEFORE THE EXPIRATION DATE THEREOF, NOTICE WILL BE DELIVERED IN ACCORDANCE WITH THE POLICY PROVISIONS.
	AUTHORIZED REPRESENTATIVE 

HISTORICALLY UNDERUTILIZED BUSINESS (HUB) DECLARATION

The primary objective of the Travis County HUB Program is to ensure Historically Underutilized Businesses receive a fair and equal opportunity for participation in the County's procurement process. This fact holds true for Services (Professional & Non-professional), Commodities, and Construction contracts and any subcontracts thereto. The program strongly encourages Prime Contractors to provide subcontracting opportunities to **Certified HUB Contractors/Vendors.**

It is the policy of the Travis County Purchasing Office to ensure a good faith effort is made to assist Certified HUB vendors and contractors in receiving contracts in accordance with the HUB Program policies and the Minority and Woman-Owned Business goals adopted by the Travis County Commissioners Court. Our goals for HUB contractor/vendor participation, as well as HUB subcontractor participation, in the area of **COMMODITIES** are as follows:

Overall MBE Goal: 3.5%; Sub-goals: 0.3% African-American, 2.5% Hispanic, .7% Native/Asian American, **Overall WBE Goal: 6.2%**

To be considered as a "Certified HUB Contractor/Vendor" the contractor/vendor must have been certified by, and hold a current and valid certification, with any of the three agencies listed below. Please attach copy of certificate.

Vendor/Contractor: Knight Security Systems

Certified as a HUB or an MBE/WBE/DBE source: Yes No HUB Status (Gender & Ethnicity): _____

If yes, by whom: St. of Tx. Bldg. and Procurement Comm. City of Austin Texas Unified Certification Program

SUGGESTED DATABASE DIRECTORIES TO VIEW WHEN SOLICITING HUB SUBCONTRACTORS

State: www.tbpc.state.tx.us/cmbl/index.html; City: www.ci.austin.tx.us/snbr/#howdoes; TUCP: www.dot.state.tx.us/business/tucpinfo.htm

LIST OF CERTIFIED HUB SUBCONTRACTORS (DUPLICATE AS NECESSARY)

_____ percent of the Bid or Proposal is to be subcontracted with Certified HUB sources: _____ % (List HUB Subcontractor information below).

Subcontractor Name: _____ HUB Status (Gender & Ethnicity): _____

Certifying Agency (Check all applicable): St. of Tx. Bldg. and Procurement Comm. City of Austin Texas Unified Certification Program

Address: _____ City: _____ State: _____ Zip: _____

Contact Person: _____ Title: _____ Phone No.: () _____

Subcontract Amount: \$ _____ Description of Work to be Performed: _____

HUB Subcontractor Name: _____ HUB Status (Gender & Ethnicity): _____

Certifying Agency (Check all applicable): St. of Tx. Bldg. and Procurement Comm. City of Austin Texas Unified Certification Program

Address: _____ City: _____ State: _____ Zip: _____

Contact Person: _____ Title: _____ Phone No.: () _____

Subcontract Amount: \$ _____ Description of Work to be Performed: _____

HUB Subcontractor Name: _____ HUB Status (Gender & Ethnicity): _____

Certifying Agency (Check all applicable): St. of Tx. Bldg. and Procurement Comm. City of Austin Texas Unified Certification Program

Address: _____ City: _____ State: _____ Zip: _____

Contact Person: _____ Title: _____ Phone No.: () _____

Subcontract Amount: \$ _____ Description of Work to be Performed: _____

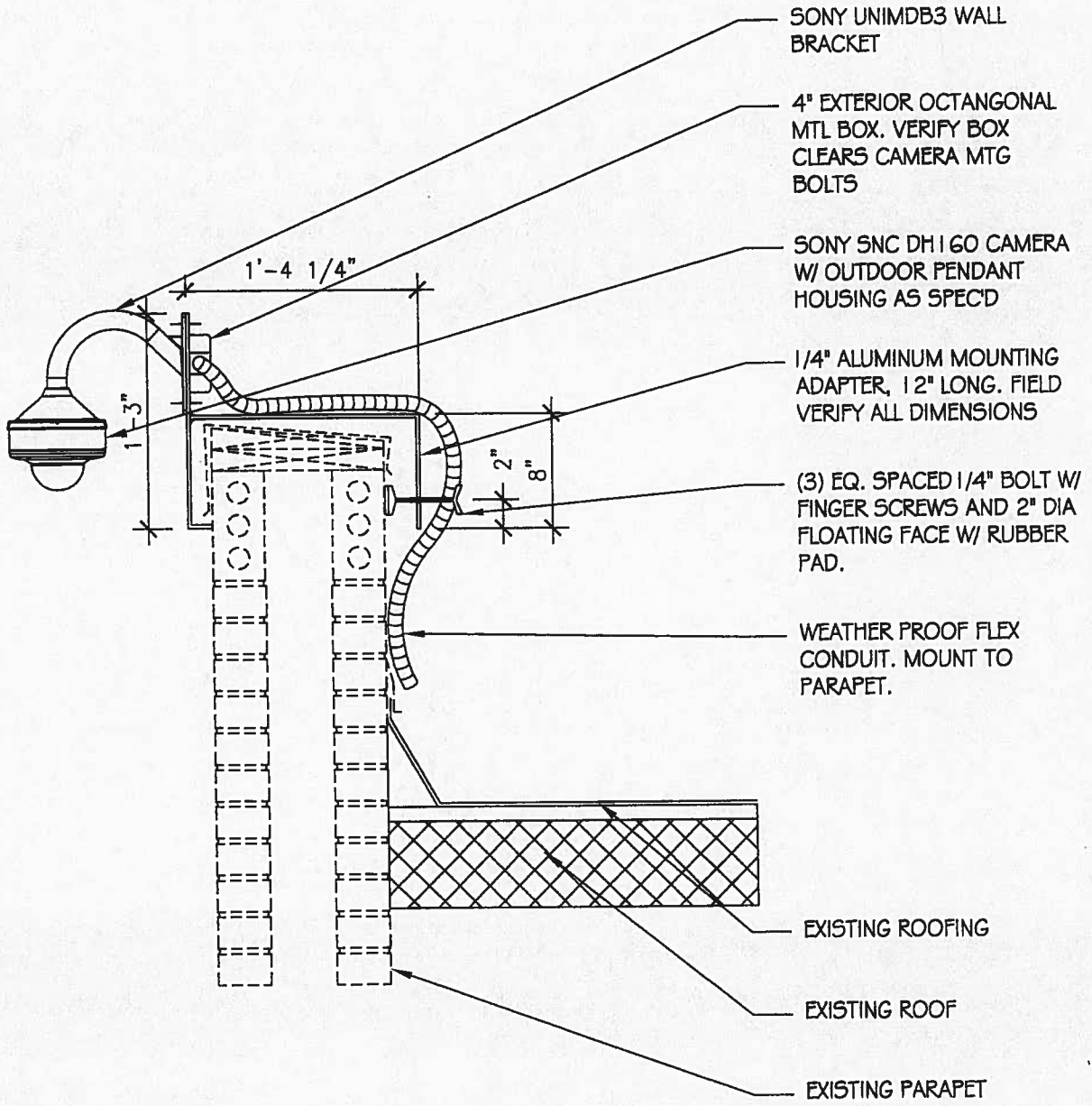

① CAMERA - CCTV DOME
ROOF MOUNTED CURVED BRACKET

SONY

Sony Electronics Inc
1 Sony Drive
Park Ridge, NJ 07656

November 23, 2011

TO WHOM IT MAY CONCERN:

Sony Electronics, Inc. is please to provide this letter certifying that Knight Security Systems, LLC with an office at 5321 Industrial Oaks Blvd, Suite 111, Austin, TX 78735 is an authorized reseller of all products offered by our company pursuant to the ultimate terms and conditions of a contract between Knight Security and Travis County as a result of RFP #P120025-GM.

Further, **Sony Electronics, Inc.** attests that Knight Security possesses the necessary technical and managerial resources and expertise required to install, configure, service and maintain these products. We recommend Knight Security based upon the company's ability develop security system designs incorporating products from **Sony Electronics, Inc.** with other related and accessory products in order to deliver an effective overall solutions to Travis County.

Sincerely,

Thomas E. Jenks
Account Manager
Sony Electronics, Inc.
Security Systems Group



November 23, 2011

Reference: OnSSI CCP Program
Knight Security, LLC

To Whom It May Concern:

Pursuant to your request for information pertaining to the OnSSI Partner Program and validation of an affiliated integration partner the following is applicable:

OnSSI maintains an extensive network of dealers and integrators through its Channel Partner Program. Organizations involved in delivering video surveillance and security solutions to the end-user community may join our Channel Partner Program and enjoy its benefits.

To be approved as an OnSSI Channel Partner, you must have a proven track record in marketing video surveillance and security systems to end users. Additionally, Certified Channel Partners must have, in active employment, at least one (1) technical support person that has been trained and certified by OnSSI to support all OnSSI's product lines.

Currently, Knight Security, LLC, at 5321 Industrial Oaks Blvd, Suite 111, Austin, TX 78735 is listed as an OnSSI Certified Channel Partner.

Please call our Sales Administration team at 845-732-7900 if we may be of any further assistance.

Regards,

Mulli Diamant
Vice President of Sales

cc. L. Duncan, OnSSI
E. Dollacker, Dollacker & Associates

On-Net Surveillance Systems, Inc.



We hereby certify that

Trey West of
Knight Security Systems

Is an OnSSI

Certified Channel Partner

2007

June 8, 2007

Date

A handwritten signature in black ink, appearing to read 'Mulli Diamant', is written over a horizontal line.

Mulli Diamant, VP of Sales, OnSSI

Texas Department of Public Safety

Certificate of License

The Texas Private Security Bureau certifies that:

KNIGHT SECURITY SYSTEMS, L.L.C.

B03566

Is Duly Licensed as

Security Contractor

Alarm Systems Company

Under the provisions of Chapter 1702 Texas Occupations Code, as amended

This License

EXPIRES: 1/31/2012

Steven C. McRae

Director, Tx Dept. of Public Safety

SNC-DH160

Network HD Mini Dome Camera — E series

SONY
make.believe

IP66 Vandal-Resistant 720p HD Security Camera with IR Illuminators

- Excellent 720p HD picture quality, supporting H.264 at 30 fps
- 1.3 Megapixel (1280 x 1024) maximum resolution
- Three codecs (H.264, MPEG-4, JPEG) and dual streaming capability
- The Exmor™ CMOS sensor incorporated to deliver high image quality and low noise



HD 1.3

KEY FEATURES

- Built-in IR (Infrared) illuminators to assist capturing objects in the dark even under 0 lx, up to 49 feet (15 m) away.

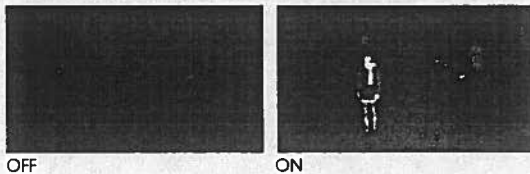

Actual images of one of Sony's HD cameras with IR illuminators.

- IP66-rated waterproof and dust-tight feature for outdoor surveillance, or indoor where water ingress may pose an issue.
- IK10-rated vandal-resistant feature to protect the camera from destructive behaviors.
- Easy Focus/Easy Zoom functions for easy installation.
- Optical Day/Night function to switch to Day or Night mode depending on the light level.
- Recording software (RealShot™ Manager Lite) is bundled to start recording and monitoring instantly.
- Stream Squared function allows simultaneous streaming of two 4:3 aspect ratio videos in user selectable SD resolutions. User can select the entire image or a portion of the image from the original field of view and resize to SD resolution or lower for each stream. With this feature, the SNC-DH160 can replace two SD cameras installed in the same line of view.

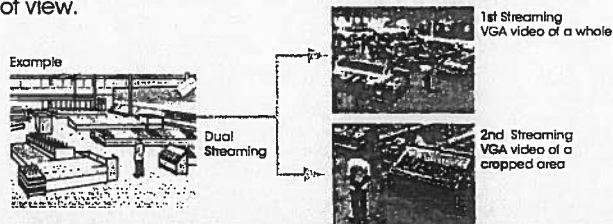

- Intelligent Motion Detection that supports DEPA™ analytics.



- Analog monitor output (phono jack).
- Powered by PoE (Power over Ethernet) for simple installation.
- Equipped with a built-in heater for continued camera operation in cold weather.
- ONVIF™ (Open Network Video Interface Forum) software that ensures greater interoperability and more flexibility in building multiple-vendor systems.

ONVIF

IPELA™

SPECIFICATIONS

SNC-DH160	
Camera	
Image device	1/3 type progressive scan Exmor CMOS sensor
Minimum illumination	0.50lx (Color), 0 lx (BW) (IR ON) (F1.2/AGC 42dB/50IRE (IP))
Number of effective pixels (H x V)	1.4 Megapixel (1329 x 1045)
Electronic shutter speed	1 s to 1/10000 s
Gain control	Auto
Exposure control	Auto, EV Compensation, Auto Slow Shutter
White balance mode	Auto (ATW, ATW-PRO), Preset, One-push WB, Manual
Lens type	Vari-focal lens
Zoom ratio	Optical 2.9X
Horizontal viewing angle	85.4 to 31.2 degrees
Focal length	f=3.1 to 8.9 mm
F-number	F1.2 (Wide), F2.1 (Tele)
Minimum object distance	300 mm
Powered focus	Yes (Easy Focus)
Powered zoom	Yes (Easy Zoom)
IR illuminators	Yes (Wave Length: 850nm [typical], IR LED: 21 pcs)
Camera Features	
Day/Night **	Yes
Noise reduction	Yes
Image	
Codec Image size (H x V)	1280 x 1024, 1280 x 960, 1280 x 800, 1280 x 720, 1024 x 768, 1024 x 576, 800 x 480, 768 x 576, 720 x 576, 720 x 480, 704 x 576, 640 x 480, 640 x 368, 384 x 288, 320 x 240, 320 x 192 (H.264, MPEG-4, JPEG)
Video compression format	H.264, MPEG-4, JPEG
Codec streaming capability	Dual streaming
Maximum frame rate	H.264: 20fps (1280 x 1024) / 30 fps (1280 x 720) MPEG-4: 25fps (1280 x 1024) / 30 fps (1280 x 720) JPEG: 30fps (1280 x 1024) / 30 fps (1280 x 720)
Scene Analytics	
Intelligent motion detection	Yes
Network	
Protocols	IPv4, IPv6, TCP, UDP, ARP, ICMP, IGMP, HTTP, HTTPS, FTP (client only), SMTP, DHCP, DNS, NTP, RTP/RTCP, RTPS, SNMP (MIB-2)
ONVIF software	Yes
Number of clients	5
Authentication	IEEE802.1X
Analog Monitor Output	
Signal system	NTSC / PAL
Interface	
Ethernet	10BASE-T / 100BASE-TX (RJ-45)
Analog monitor output	Phono jack x 1
Sensor input	x 1, make contact, break contact
Alarm output	x 1, 24V AC/DC, 1A (Mechanical relay outputs electrically isolated from the camera)
General	
Weight	2 lb 15 oz (1320 g)
Dimensions (w x h)	ø 6 5/8 x 4 3/4 inches (166 x 119 mm)
Power requirements	PoE
Power consumption	12.9 W max
Starting temperature	-4°F to +122°F (-20°C to +50°C)
Working temperature	-22°F to +122°F (-30°C to +50°C)
Storage temperature	-4°F to +140°F (-20°C to +60°C)
Ingress protection	IP66
Vandal resistant	IK10
Safety regulation	UL2044, FCC 15B Class A, IC Class A, IEC60950-1, EN55022(A)+EN55024+EN50130-4, VCCI Class A, C-Tick Class A
System Requirements	
Operating system	Microsoft Windows XP™, Windows Vista™ (32bit), Windows® 7 (32bit)
Processor	Intel Core2 Duo 2 GHz or higher
Memory	1 GB or more
Web browser	Microsoft Internet Explorer® Ver. 6.0, Ver. 7.0, Ver. 8.0 Firefox® Ver.3.5 (Plug-in free viewer only) Safari® Ver.4.0 (Plug-in free viewer only) Google® Chrome Ver.4.0 (Plug-in free viewer only)
Supplied/Accessories	
	CD-ROM (User's Guides, SNC Toolbox), Installation Manual, Bracket, Template, Wire rope, Camera unit mounting screws (4), Shoulder screw M4, I/O cable, LAN cable, B&P Warranty Booklet

*1 Removable IR Cut Filter.

**The SNC-DH160 includes software developed by the OpenSSL Project for use in the OpenSSL Toolkit (<http://www.openssl.org/>).

SYSTEM CONFIGURATIONS

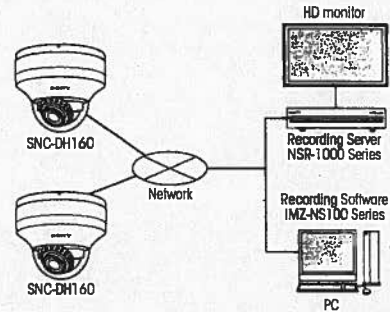

DIMENSIONS

Unit: inches (mm)

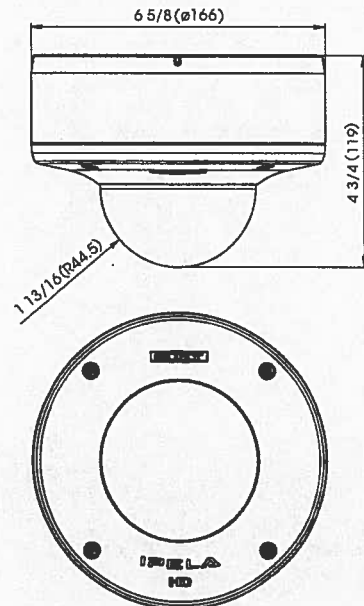

© 2010 Electronics Inc. All rights reserved.
Reproduction in whole or in part without written permission is prohibited.
Features and specifications are as subject to change without notice.
Sony, 'make.believe', iPELA, DEIRA, Exmor, OnVIF and their respective logos are trademarks of Sony.
Windows, XP, and Vista are trademarks of Microsoft Corporation.
All other trademarks are the property of their respective owners.

Sony Electronics Inc.
1 Sony Drive
Park Ridge, NJ 07656
sony.com/security

S-IP2079 (MIK10733V1)

Printed in USA (10/10)

SNC-DH180

Network HD Mini Dome Camera — V Series

SONY
make.believe

HD Security Camera with IR Illuminators and View-DR Technology



Sony is pleased to introduce a powerful addition to its network HD camera lineup, the SNC-DH180. This vandal-resistant, wide dynamic range camera is designed with a built-in infrared (IR) illuminators. As a dual-stream network camera, it supports H.264, MPEG-4, and JPEG compression formats, and delivers excellent picture quality in HD 720p resolution at 30 frames per second (fps).

Incorporating the new Exmor™ CMOS image sensor from Sony, which is specially designed for surveillance applications, this rugged camera features state-of-the-art image-enhancement technology, View-DR™, which delivers an extremely wide dynamic range. The SNC-DH180 also features an IR illuminators to deliver quality images even in absolute darkness (0 lx)*1. Along with a host of superb features such as DEPA™ Advanced, PoE, a built-in heater, and the Easy Focus/Easy Zoom functions, the SNC-DH180 Mini Dome Network Camera is ideal for the most demanding surveillance applications.



HD

FEATURES

- Excellent picture quality in HD 720p resolution, supporting H.264 at 30 fps **HD**
- 1.3 Megapixel (1280 x 1024) maximum resolution
- The Exmor CMOS sensor delivers high image quality and high sensitivity for surveillance **Exmor.** 
- Clearly captures objects in the dark up to 49 feet (15 m) away with IR illuminators, which allow the camera to operate in 0 lx lighting conditions *1 (Images 1)
- Wide dynamic range achieved by the innovative View-DR (Visibility enhanced wide Dynamic Range) technology (Images 2) **View-DR**
 - ▶ Full-capture Wide-D technology – all of the electrons converted from the captured light are fully used
 - ▶ High-speed Exmor CMOS sensor
 - ▶ Visibility enhancer technology
- The Visibility Enhancer optimizes contrast and makes the subject more visible, even in severe backlight or shadow conditions
- XDNR™ (eXcellent Dynamic Noise Reduction) technology for clear images without motion blur under low illumination (Images 3)
- Easy Focus / Easy Zoom functions for easy installation
- DEPA Advanced Intelligent Video and Audio Analytics trigger an alarm, based on user-defined rules
 - ▶ Intelligent Motion Detection 
 - ▶ Tamper Alarm
- Three codecs (H.264, MPEG-4, JPEG) with dual streaming capability
- Power over Ethernet (PoE) capability
- Built-in heater for use in cold
- IP66-rated
- ONVIF™ software (Open Network Video Interface Forum) **ONVIF**

Drastic Improvement in Visibility

IR Illuminators (Images 1)

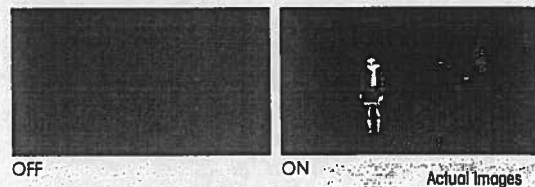

View-DR Technology (Visibility enhanced wide Dynamic Range) (Images 2) **View-DR**

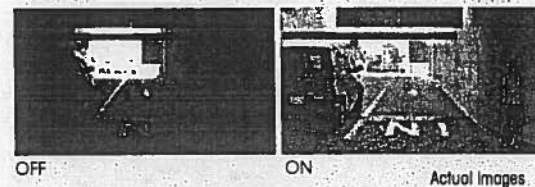

XDNR™ Technology (eXcellent Dynamic Noise Reduction) (Images 3)

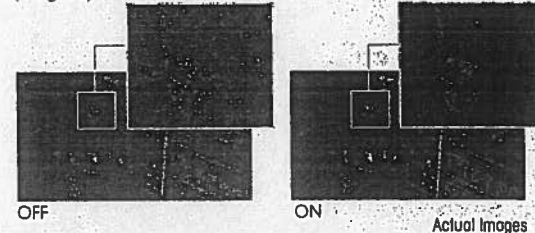

*1 0 lx requires the use of IR illuminators.
IR rays are not visible to the human eye.
When the IR illuminators is activated, the image is in black and white.

IPELA™

SPECIFICATIONS

SNC-DH180	
Camera	
Image device	1/3 type progressive scan Exmor CMOS sensor
Minimum illumination	0.2 lx (Color) / IR ON (F1.2 / View-DR ON/AVE Off / AGC High (4dB max.) / XDNR Middle / SDRP (P1))
Number of effective pixels (H x V)	1.4 Megapixels (1328 x 1049)
Electronic shutter speed	1s to 1/10000s
Gain control	Auto (3 levels)
Exposure control	Auto, EV Compensation *, Auto Slow Shutter *
White balance mode	Auto (AWB, ATW-PRO), Preset, One-push WB, Manual
Lens type	Vari-focal lens
Zoom ratio	Optical 2.9X (x2 Digital Zoom)
Horizontal viewing angle	85.4 to 31.2 degrees
Focal length	f=3.1 to 8.9 mm
F-number	F1.2 (wide), F2.1 (tele)
Minimum object distance	300 mm
Powered Focus	Yes (Easy Focus)
Powered Zoom	Yes (Easy Zoom)
IR illuminators	Yes (Wave Length: 850nm [Typical], IR LED: 21pcs)
Camera Features	
Day/Night **	Yes
Wide-D	View-DR Technology (130 dB)
Image enhancement	Visibility Enhancer
Noise reduction	XDNR Technology
Image	
Codec image size (H x V)	1280 x 1024, 1280 x 960, 1280 x 800, 1280 x 720, 1024 x 768, 1024 x 576, 800 x 480, 768 x 576, 640 x 480, 640 x 368, 384 x 288, 320 x 240, 320 x 192 (H.264, MPEG-4, JPEG)
Video compression format	H.264, MPEG-4, JPEG
Codec streaming capability	Dual streaming
Maximum frame rate	H.264: 20fps (1280 x 1024) MPEG-4: 25fps (1280 x 1024) JPEG: 30fps (1280 x 1024) H.264/MPEG-4/JPEG: 30 fps (1280 x 720)
Audio	
Audio compression	G.711/G.726
Security Analytics	
Intelligent motion detection	Yes (with built-in Post Filter)
Intelligent object detection	No
Rule filter	Yes
Network	
Protocols	IPv4, IPv6, TCP, UDP, ARP, ICMP, ICMP, HTTP, HTTPS, FTP (client/server), SMTP, DHCP, DNS, NTP, RTP/RTCP, RTSP, SNMP (MIB-2)
ONVIF software	Yes
Wireless network	No
Number of clients	10
Authentication	IEEE802.1X
Analogue Video Output	
Signal system	NTSC/PAL
Horizontal resolution	600 TV lines
S/N ratio	More than 50dB
Interface	
Ethernet	10BASE-T / 100BASE-TX (RJ-45)
Serial interface	No
Card slots	No
Analogue video output	BNC x 1, RCA x 1
Sensor input	x 1
Alarm output	x 2
External microphone input	Mini-jack (Monaural), MIC IN/LINE IN: 2.5VDC plug-in power
Audio line output	Mini-jack (Monaural), Max output level: 1 Vrms
General	
Weight	3 lb 1 oz (1380 g)
Dimensions (w x h)	6 5/8 x 4 3/4 inches (166 x 119 mm)
Power requirements	PoE **: AC24V, DC12V
Power consumption	28 W max.
Starting temperature	AC24V/DC12V: -4 to 122°F (-20 to 50 °C) PoE (IEEE802.3af): 32 to 122°F (0 to 50 °C)
Working temperature	AC24V/DC12V: -22 to 122°F (-30 to 50 °C) PoE (IEEE802.3af): 23 to 122°F (-10 to 50 °C)
Storage temperature	-4°F to 140 °F (-20°C to +60°C)
Ingress Protection	IP66
Vandal Resistant	IK10
System Requirements	
Operating system	Windows XP™, Windows Vista™
Processor	Intel Core2 Duo 2 GHz or higher
Memory	1 GB or more
Web browser	Microsoft Internet Explorer® Ver 6.0 or 7.0
Supplies/Accessories	
CD-ROM (User's Guide, SNC Toolbox), Installation manual, Wire rope, Bracket, BNC cable, VD cable, Audio cable, M4 shoulder screw, M4 screw x 4, Pliers, L-wrench, B&P Warranty Booklet, Template	

*1 VE off mode only. *2 View-DR off mode only. *3 Removable IR Cut Filter. *4 When used with PoE, SNC-DH180 cannot be used with a heater.
The SNC-DH180 includes software developed by the OpenSSL Project for use in the OpenSSL Toolkit (<http://www.openssl.org/>).

SYSTEM CONFIGURATIONS

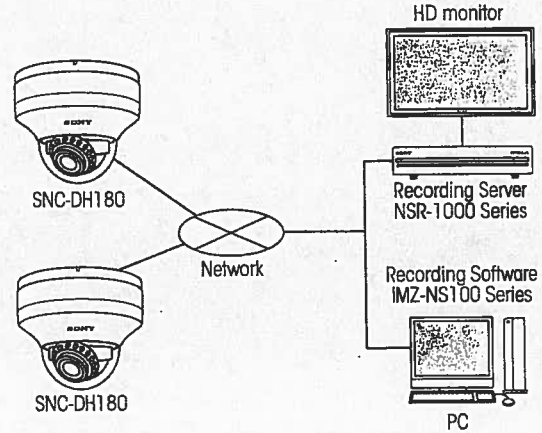

DIMENSIONS

Unit: inches (mm)

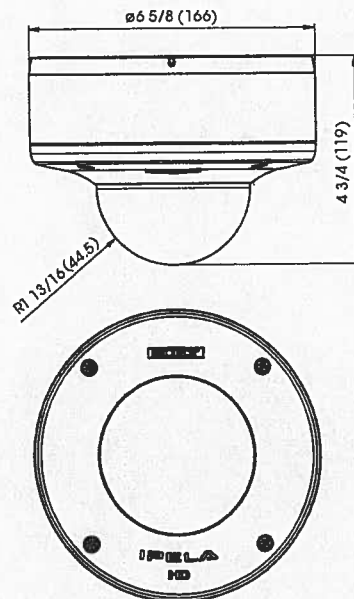

SONY[®]

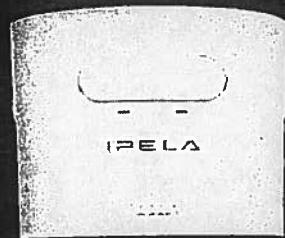

SNC-RS44N/SNC-RS46N
Indoor Model

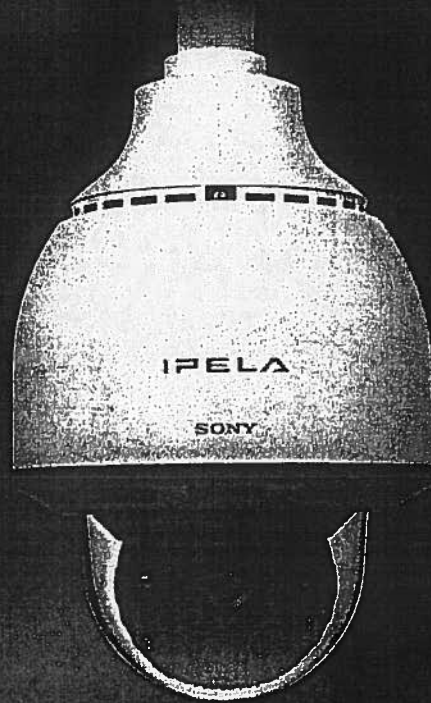

SNC-RS84N/SNC-RS86N
Outdoor Model

Network Rapid Dome Cameras
SNC-RS Series

New Rapid Dome Cameras from Sony – High Visibility, Feature Rich, and a Choice of Models

Sony is pleased to introduce its new rapid dome cameras, the SNC-RS Series, which support H.264, MPEG-4, and JPEG compression formats. With a powerful streaming capability of 30 fps in D1 resolution, combined with newly developed image-enhancement technologies, the SNC-RS Series dramatically enhances usability in a wide variety of lighting environments and applications. Plus, a total 210° tilt range and 360° endless high-speed pan capability allows users to view images above the horizon. This feature provides great installation flexibility for a number of different applications and locations. With a host of new features and excellent performance, the SNC-RS Series is the perfect choice, for your security surveillance needs.

FEATURES

Clear and Bright HD Images

Visibility Enhancer

The SNC-RS Series includes Visibility Enhancer technology. This tone-correction technology optimizes the visibility of a scene by increasing brightness in darker areas of the scene and compressing the brighter areas. The result is sharper, clearer images and a higher level of visibility – all of which are critical for security surveillance.

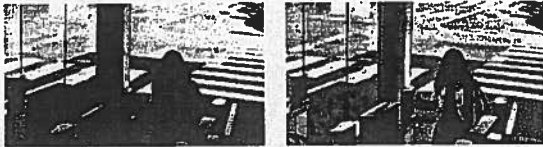

OFF ON (Actual Images)

XDNR (eXcellent Dynamic Noise Reduction)

Incorporating newly developed XDNR technology, these cameras can provide clear images while at the same time minimizing motion blur under low illumination. What's more, when both XDNR and Visibility Enhancer are turned on, the cameras can achieve up to four times the sensitivity compared to when they are off.

This technology is ideal for any outdoor surveillance monitoring, such as a car parked at night.

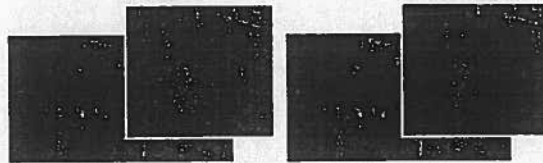

OFF ON (Actual Images)

Wide-D Technology

The SNC-RS Series incorporates Wide-D technology, which offers a wide dynamic range to handle various lighting conditions in a scene. Even in a scene with extremely bright and dark areas, or in backlight conditions, the SNC-RS Series provides clear visibility of all objects.

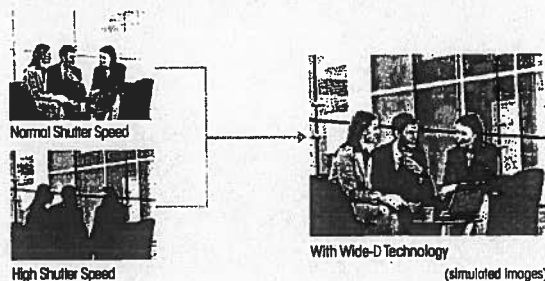

Powerful and Versatile Zoom Capability

The SNC-RS46/RS86 incorporates a powerful 36x optical zoom lens, while the SNC-RS44/RS84 incorporates a 18x optical zoom lens. Both also feature a 12x digital zoom capability, providing a total zoom ratio of 432x for the SNC-RS46/RS86 and 216x for the SNC-RS44/RS84.

Intelligence

DEPA Advanced – Intelligent Video and Audio Analytics

Incorporating DEPA™ Advanced technology, the SNC-RS Series offers intelligent video and audio analytics. With this feature, the camera can trigger an alarm based on rules. This allows users to further refine the criteria for triggering an alarm, making the overall system more efficient.

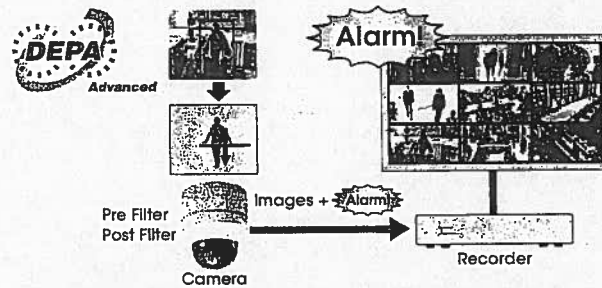

• Intelligent Motion Detection

With this feature, the cameras can detect irregular motion and trigger an alarm based on up to three user-defined rules, such as intrusion across a virtual border line or a beam intrusion detector*1.

• Tamper Alarm

When an attempt is made to tamper with the camera, such as spray-painting the lens, the SNC-RS Series detects this and triggers an alarm. This event can be used to activate the camera relays, or even to start the Voice Alert function.

• Advanced Audio Detection*2

Unlike conventional audio detection where an alarm is triggered based on a preset audio level, the SNC-RS Series triggers its alarms based on ambient sound conditions as the threshold. The camera stores and updates ambient audio levels and frequencies, and when the threshold level based on this data is surpassed, an alarm is triggered.

Audio Functions

Voice Alert

The camera can store up to three pre-recorded audio files. Upon initiation, either manually or via an alarm, the camera can play out one of the three pre-recorded audio files via a locally connected active speaker.

Ambient Sound Filter

The SNC-RS Series is capable of learning ambient sound and suppressing extraneous noise.

Dynamic Range Compressor*2

To prevent audio clipping from occurring due to high audio levels, these cameras employ the dynamic range compressor, which dynamically controls the gain to maintain incoming audio at a proper level.

Echo Cancellation

The SNC-RS Series has an echo-cancellation capability. This feature cancels the echo that would otherwise occur between the operator site and the camera site, when loud speakers and microphones are used in the system.

System Flexibility

Three Codecs – H.264, MPEG-4, and JPEG Support

The SNC-RS Series supports three compression formats: H.264, MPEG-4, and JPEG. The industry-standard JPEG compression format is the best choice for high-quality still images. MPEG-4 provides clear moving images efficiently over networks when bandwidth is limited. H.264 provides twice the efficiency of MPEG-4, for when bandwidth is even more limited.

Dual-encoding Capability

With its dual-encoding capability, the SNC-RS Series can stream any two formats from H.264, MPEG-4, and JPEG, simultaneously. This flexibility allows you to maximize your network and storage resources.

ONVIF Conformance (Open Network Video Interface Forum)

In line with Sony's commitment to open standards, the SNC-RS Series conforms to ONVIF software specifications. ONVIF™ defines a common protocol for the exchange of information between different network video devices regardless of manufacturer, and realizes greater interoperability in multi-vendor network video systems.

Support for IPv6

The SNC-RS Series supports Internet Protocol Version 6 (IPv6).

Advanced Rapid Dome Mechanis

Above-the-Horizon Tilt – 15° Tilt-up

The SNC-RS Series has a total tilt range of 210°. Thanks to this additional 15° tilt range compared to the normal horizon-only view, the SNC-RS Series is able to monitor elevated areas – which greatly expands its viewing range.

High-speed 360° Endless Panning

The SNC-RS Series has a high-speed 360° endless panning (or rotation) capability, as fast as 400° per second. This allows users to quickly and precisely capture almost any object within the field of view surrounding the camera.

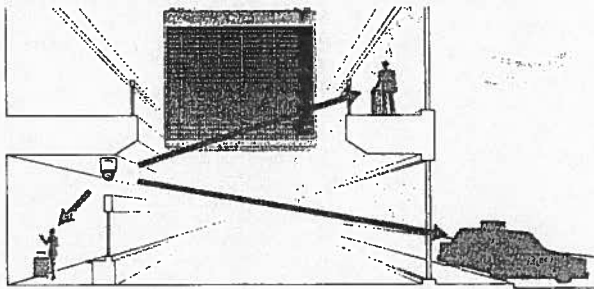

Flexible and Easy Installation

Quick-release Mechanism

The camera can be installed or detached quickly and easily thanks to its newly developed base, which greatly reduces installation and servicing time.

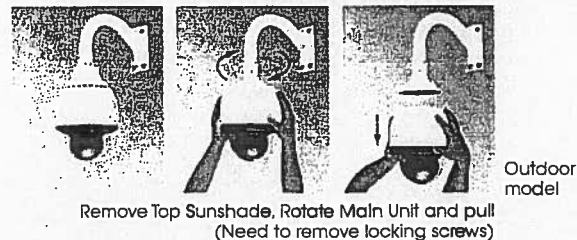

hPoE Support*³ (Compliant With IEEE802.3)

Supporting high Power over Ethernet (hPoE), the SNC-RS44/RS46 can be powered using the same Ethernet cable it uses for data transfer. This feature greatly reduces the physical infrastructure costs and speed of deployment.

Local Storage / Wireless Capability

The SNC-RS Series has a CompactFlash® slot. This can be used either with a CompactFlash memory card for local video storage, or for wireless capability. The SNCA-CFW5 (802.11b/g) CompactFlash type wireless LAN card is supported.

Designed for Heavy-duty Outdoor Monitoring (SNC-RS84/RS86)

IP66 Rating

The SNC-RS84/RS86 complies with the IP66 standard for protection against water and dust.

Hard Coated Dome Cover

The camera is protected by an impact-resistant polycarbonate dome cover.

Integrated Sunshade and Ventilation Mechanism

For outdoor applications, the camera comes standard with a sunshield and special ventilation mechanism.

*1 Beam intrusion detector is available with version 1.1 or later

*2 Available with version 1.1 or later

*3 Available with version 1.2 or later

OPTIONAL ACCESSORIES

Indoor



YT-LD124C
Dome Cover Clear

Indoor



YT-LD124S
Dome Cover Smoked

Indoor



YT-ICB124
In-ceiling Bracket

Outdoor

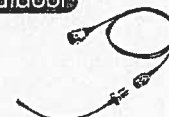

SNCA-CW5
Outdoor Antenna Cable Kit

Indoor Outdoor



SNCA-CFW5
Wireless LAN Card

Indoor Outdoor



SNCA-AN1
Wireless LAN Antenna

CONNECTORS

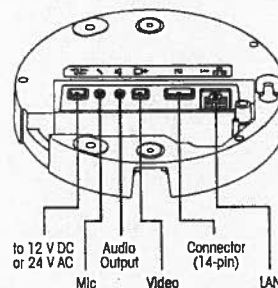

SNC-RS44/RS46

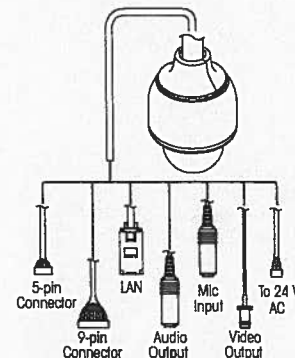

SNC-RS84/RS86

SPECIFICATIONS

	SNC-RS46N/RS86N (V33)	SNC-RS46P/RS86P (V33)	SNC-RS44N/RS84N (V18)	SNC-RS44P/RS84P (V18)
Image device	1/4-type CCD with Emvive HAD technology			
Minimum illumination	Indoor Model Day : 0.7 lx (XDR ON VE ON Slow Shutter OFF 50 IRE IP) 1.4 lx (Slow Shutter OFF 50 IRE Analog Video Output) Night : 0.06 lx (XDR ON VE ON Slow Shutter OFF 50 IRE IP) 0.15 lx (Slow Shutter OFF 50 IRE Analog Video Output)		Day : 0.4 lx (XDR ON VE ON Slow Shutter OFF 50 IRE IP) 0.7 lx (Slow Shutter OFF 50 IRE Analog Video Output) Night : 0.06 lx (XDR ON VE ON Slow Shutter OFF 50 IRE IP) 0.15 lx (Slow Shutter OFF 50 IRE Analog Video Output)	
	Outdoor Model Day : 0.8 lx (XDR ON VE ON Slow Shutter OFF 50 IRE IP) 1.4 lx (Slow Shutter OFF 50 IRE Analog Video Output) Night : 0.09 lx (XDR ON VE ON Slow Shutter OFF 50 IRE IP) 0.17 lx (Slow Shutter OFF 50 IRE Analog Video Output)		Day : 0.4 lx (XDR ON VE ON Slow Shutter OFF 50 IRE IP) 0.8 lx (Slow Shutter OFF 50 IRE Analog Video Output) Night : 0.09 lx (XDR ON VE ON Slow Shutter OFF 50 IRE IP) 0.17 lx (Slow Shutter OFF 50 IRE Analog Video Output)	
Number of effective pixels (H x V)	380,000 (768 x 494)	440,000 (752 x 582)	380,000 (768 x 494)	440,000 (752 x 582)
Electronic shutter speed	1 to 1/10,000 s			
Auto gain control	Auto/Manual (-3 to +28 dB)			
Exposure control	Auto, Full auto, Shutter-priority, Iris-priority, Manual, EV compensation, Backlight compensation			
White balance mode	Auto, Indoor, Outdoor, One-push WB, AIW, Manual			
Lens type	Auto-focus zoom lens			
Zoom ratio	3lx		1lx	
Horizontal viewing angle	1.7 to 57.8 degrees		2.8 to 48.0 degrees	
Focal length	f=3.4 to 122.4 mm		f=4.1 to 73.8 mm	
F-number	F1.6 (wide), F4.5 (tele)		F1.4 (wide), F3.0 (tele)	
Minimum object distance	12 5/8 inches (320 mm) (wide) to 59 1/8 inches (1500 mm) (tele)		11 1/8 inches (290 mm) (wide) to 31 1/2 inches (800 mm) (tele)	
Pan angle	360 degrees endless rotation			
Pan speed	400 degrees/s (max.)			
Tilt angle	210 degrees (with e-tip)			
Tilt speed	400 degrees/s (max.)			
Camera features				
Day/Night	Yes			
Wide-D	Yes			
Visibility Enhancer	Yes			
XDR	Yes			
Image bus	IEEE1394b			
Codec image size (H x V)	720x480 (NTSC), 720x576 (PAL), 640x480 (VGA), 384x288, 320x240 (QVGA)			
Video compression format	H.264, MPEG-4, JPEG	H.264/MPEG-4/JPEG	H.264/MPEG-4/JPEG	H.264/MPEG-4/JPEG
Maximum frame rate	H.264/MPEG-4/JPEG: 30 fps (720 x 480)	25 fps (720 x 576)	30 fps (720 x 480)	25 fps (720 x 576)
Audio compression	G.711/G.726			
Scene analysis				
Intelligent motion detection	Yes (with built-in Post Filter)			
Intelligent object detection	No			
Advanced audio detection	Yes ¹			
Network protocols	IPv4, IPv6, TCP, UDP, ARP, ICMP, IGMP, HTTP, HTTPS, FTP (client/server), SMTP, DHCP, DNS, NTP, RTP/RTCP, RTPS, SNMP (MIB-2)			
Wireless network	Yes (with optional **)			
Number of clients	10			
Authentication	IEEE802.1X			
Analog video output				
Signal system	NTSC	PAL	NTSC	PAL
Horizontal resolution	530TVL			
SN ratio	more than 50 dB			
Interface				
Ethernet	10BASE-T/100BASE-TX (RJ-45)			
Serial interface	RS-232C, RS-422/RS-485 (PELCO D protocol)			
Card slots	CF card x1			
Analog video output	Composite video (1Vp-p)			
Sensor input	x 4			
Alarm output	x 2			
External microphone input	Mini-jack (Monaural), MIC IN/LINE IN: 2.2k ohm, 2.45VDC plug-in power			
Audio line output	Mini-jack (Monaural), Max output level: 1Vrms			
General specifications				
Weight	Indoor Model Approx. 4 lb 6 oz (2.0 kg)		Outdoor Model Approx. 9 lb 8 oz (4.3 kg)	
Dimensions (ø x H)	Indoor Model 6 1/8 x 9 inches (154 x 226 mm)		Outdoor Model 9 3/8 x 13 5/8 inches (238 x 344 mm)	
Power requirements	Indoor Model AC24V		Outdoor Model AC24V, DC12V	
Power consumption	Indoor Model 23 W max.		Outdoor Model 78 W max.	
Operating temperature	Indoor Model 32 to 122 °F (0 to 50 °C)		Outdoor Model -40 to +122 °F (-40 to +50 °C)	
Storage temperature	-4 to +140 °F (-20 to +60 °C)			
System requirements				
Operating system	Windows [®] XP, Windows Vista [™]			
Processor	CPU: Pentium [®] 4 3GHz, Intel Core [™] 2 Duo 2GHz or higher			
Memory	1GB or more			
Web browser	Microsoft Internet Explorer [®] Ver6.0 or Ver7.0			
Supplied accessories	Indoor Model Base unit, Mounting bracket, Screws, Cables (Power input, BNC, I/O, Serial), Installation manual, CD-ROM (User's guide, SNC toolbar), Mounting template, Wire rope		Outdoor Model Top sunshade, Rotate-and-lock coupling, Waterproof covers, Bolts, Installation manual, CD-ROM (User's guide, SNC toolbar), Wire fishing bell, Cables	

¹ Removable IR Cut Filter ² DynaView Technology ³ Available with software version 1.1 or later ⁴ With optional SNCA-CFWS
⁵ Available with software version 1.2 or later

SYSTEM CONFIGURATIONS

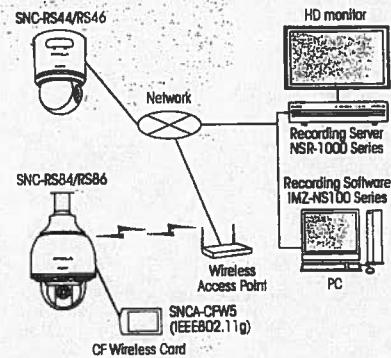

DIMENSIONS

SNC-RS44/RS46

SNC-RS84/RS86

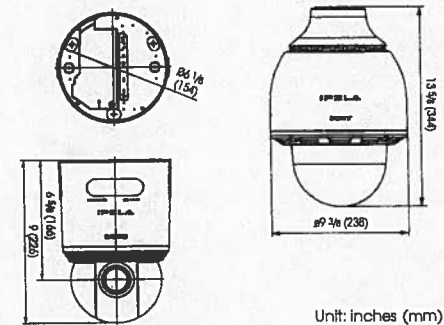

Unit: inches (mm)

CONFIGURATION

SNC-RS84/RS86

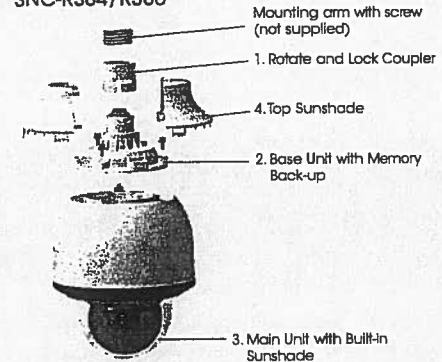

Install in indicated numerical order

^{*} This product includes software developed by the OpenSSL Project for use in the OpenSSL Toolkit. (<http://www.openssl.org/>)

SONY

Sony Electronics Inc.
 1 Sony Drive
 Park Ridge, NJ 07656
 click: sony.com/security

S-IP2046 (MK10605V1)

© 2009 Sony Electronics Inc. All rights reserved.
 Reproduction in whole or in part without written permissions is prohibited.
 Features and specifications are as of version 1.2 or later and subject to change without notice.
 All non-metric weights and measurements are approximate.
 Sony, the Sony logo, DRViE, iPELA and DEPA are trademarks of Sony.
 Windows XP, Windows Vista and Internet Explorer are trademarks of Microsoft Corporation.
 CompactFlash is a trademark of the CompactFlash Association.

Printed in USA (9/09)

George R. Monnat

From: Bob Minchew <bminchew@knightsecurity.com>
Sent: Tuesday, December 06, 2011 10:57 AM
To: George R. Monnat
Subject: RE: Knight Proposal - RFP P120025-GM

Hello Mr. Monnat,

2.5 Description of Proposer – must include:

- The number of employees both inside and outside of Travis County,

Knight Security Systems currently employ 59 employees.

2.6 Proposer Representative –

name of the designated individual(s), along with respective telephone numbers, who will be responsible for answering technical, functional, and contractual questions with respect to the proposal

All questions regarding Travis County will be handled from the Austin office (512)892-8801

Technical Questions:

Jason Chilek x102

Thomas Marik x114

Functional:

SecurePlan Customers (877) 590-7990 or (512)892-8801 Chris Shelton x113 or Roy Hall x101

Contractual: Bob Minchew x106

*Kind Regards,
Bob Minchew
Director Business Development
512-892-8801 Office
512-891-0283 Fax
512-775-2220 Cell*



From: George R. Monnat [mailto:George.Monnat@co.travis.tx.us]
Sent: Tuesday, December 06, 2011 9:52 AM
To: bminchew@knightsecurity.com
Subject: Knight Proposal - RFP P120025-GM

Mr. Minchew,



ATTACHMENT D

SecurePlan Administration Policy

January 1, 2012

Knight Security Systems **SecurePlan** service level agreement is a comprehensive and extensive customer support program that includes routine preventative maintenance, priority support, software upgrades, and premium service plan. **SecurePlan** may also include system health monitoring that will alert Knight Security of system issues proactively.

The **SecurePlan** agreement covers the operation of an electronic system for the term specified in the signed agreement between Knight Security Systems and our customer. **SecurePlan** coverage is limited to the list of equipment provided by Knight Security and agreed upon by the Customer. If no such list was provided by Knight, the equipment covered is limited to that equipment installed by Knight Security within 90 days immediately prior to the date on the **SecurePlan** agreement.

Priority Dispatch with GUARANTEED Same Day Service

SecurePlan customers receive PRIORITY DISPATCH SERVICE. If a service request is received by Knight Security from a customer with a current **SecurePlan** agreement in effect, and in accordance with the service call procedures provided by Knight Security Systems on a normal business day, Knight Security will initiate a response to address the reported issue before 5pm of that business day. Should the request for service be received after noon, Knight Security will respond no later than 5pm of the next business day. Failure by Knight Security to respond within these parameters shall result in a credit to the customer's account equivalent of one month of **SecurePlan** service. For customers with multi-location **SecurePlan** agreements, this credit shall be limited to the location of the service request only.

Knight Security personnel will evaluate the reported issue and make a determination regarding the best course of action to remedy the issue. In some cases, Knight Security's service response will consist of remote troubleshooting, diagnosis and resolution of the issue. In such cases, Knight Security, having responded in accordance with the above prescribed timeframes, will have rendered Service in accordance with this policy. Alternatively, Knight Security may dispatch a service technician to the site to investigate and resolve the issue in accordance to the response policy above. Priority Dispatch does not guarantee that a particular system issue will be entirely resolved within on the same day. Priority Dispatch guarantee shall not apply to service requests not covered by **SecurePlan**, regardless of when the determination of non-coverage is made.

This document and all attachments are solely for the use of client personnel. No part of it may be circulated, quoted, or reproduced for distribution outside the client organization without prior written approval from Knight Security Systems LLC.



Labor and travel cost during normal business hours is included.

Services under the **SecurePlan** agreement shall be performed during Knight Security's normal business hours which are generally, Mon-Fri, 8:00am to 5:00pm, excepting major national holidays. All the labor cost, including travel time, for service work qualifying under this **SecurePlan** agreement are provided at no charge. Additional charges for labor and travel will apply for service responses made the Knight Security that do not qualify under the **SecurePlan** coverage. Evening or weekend service requested by the customer will incur additional charges, minimum 2 hours. Note: normal business hours response (whether on site or remotely delivered service) may require that the Knight Security technician work past 5pm to resolve a customer issue, this event does not constitute evening service rates. Knight Security will strive to resolve the system issue at each service event; however, we may require additional service time on site. If Knight determines an additional trip will be required, this service call will be scheduled for the next business day, or at the customer's convenience.

SecurePlan provides a 25% discount on labor rates

As a **SecurePlan** customer, a 25% discount shall be apply to all chargeable service labor rates charged as well as labor related to system additions. For Service labor, this discount applies to all billable work performed on components covered by SecurePlan at a particular location. For System additions, a 25% discount on labor will be applied to all system additions which are less than 50% of the initial value of the system covered by SecurePlan at this location. Should the customer have systems serviced or installed by Knight Security that are not covered by SecurePlan, this labor discount would not apply.

Device repair or replacement

As long as the **SecurePlan** agreement is in effect (which may be long after the manufacturer warranty expires), Knight will repair or replace any defective part of the System without charge to Purchaser, including consumable components (i.e. batteries) and parts that fail due to normal wear and tear on the system. Knight may use new or used parts of the same quality. Knight may keep all replaced components.

SecurePlan does not cover repairs that are needed because of any accident, act of God, vandalism, terrorism, misuse or abuse of the System, customer's failure to properly use the System, system service or programming changes made by anyone other than Knight Security, or a Knight Security authorized service provider, or any other reason except a defect in the



equipment or Knight's installation. Service labor and materials provided by Knight Security which are excluded from [SecurePlan](#) coverage will be charged to customer.

System software upgrades and license fees

The [SecurePlan](#) agreement includes manufacturer system software maintenance coverage over the term of the agreement. While software maintenance plans and coverage may vary slightly among manufacturers, generally this will provide for all software patches and new major software releases. Unless required to remedy a system issue covered by [SecurePlan](#), Knight Security will apply eligible software patches and upgrades during the next scheduled system maintenance period.

Knight Security, at its discretion, may refrain from implementing software upgrades or patches for which the customer may be eligible if Knight Security's anticipates that the upgrade would jeopardize system stability or performance. In some cases, upgrading of system software may require an upgrade to underlying system hardware, or computers accessing the system. [SecurePlan](#) does not cover upgrade of system hardware or computers that may be required to accommodate software upgrades.

FREE Loaner Equipment

In some cases, system components may need to be sent to the manufacture to be repaired – even if covered by the manufacturer warranty. Such repairs may take several weeks and incur shipping charges. In cases where failed system components must be repaired or replaced, Knight Security will substitute a component of similar quality and function within 3 business days of the service request until such time as the permanent component is available. Provided the loaner replacement component is of equal or higher quality, Knight Security may, at its discretion, elect to leave the replacement loaner unit as a permanent service replacement part of the system and continue to be covered under the [SecurePlan](#) as original equipment. Knight Security will also cover all shipping costs for the repair.

Scheduled Functional Tests

Based upon the terms of the [SecurePlan](#) agreement, Knight Security will schedule annual, quarterly or monthly visits to your site for a technician to test overall functionality and operation of the system as well as conduct a physical inspection of all components. If repairs are required and qualify under [SecurePlan](#), Knight Security Systems will provide repairs to the system and the equipment. If component damage or deficiencies are discovered that are not

This document and all attachments are solely for the use of client personnel. No part of it may be circulated, quoted, or reproduced for distribution outside the client organization without prior written approval from Knight Security Systems LLC.



covered by SecurePlan Knight Security technician will note the deficiency and advise the Customer of an estimated cost to perform a repair. Further, if software patches or upgrades are available for the system, this updates will be applied during the scheduled Preventative Maintenance . All activity shall be documented in an inspection and test report provided to the Customer.

System Health Monitoring

Selection of the System Health Monitoring Option in conjunction with a *SecurePlan* agreement, allows Knight Security to automatically receive alerts from your system. The types of alerts will vary with each system and may include hard drive failure, power outages, network outages, or component failure. These alerts will enable Knight Security to proactively identify and respond to system issues without the need for a service call. Knight Security does NOT review or monitor video or security related alarms arising from normal system operations except for purposes of resolving system issues.

Should Knight Security personnel receive a system generated alert, Knight Security will initiate a service order and a response as deemed appropriate including the initiation of remote diagnostic activity prior to notification of the customer. In accordance with the *SecurePlan* priority response policy, System Heath Monitoring alert received before noon on a standard business shall be addressed before 5pm the same day. Alerts received after 12 noon, Knight Security will respond no later than 5pm of the next business day.

The System Health Monitoring requires a network connection from the monitored system to the Internet in order to connect with the Knight Security system health monitoring platform. Knight Security will utilize methods to establish a secure network connection between the Customer location and the Knight Security Customer Support Center. Unless specifically indicated in the *SecurePlan* agreement, the Customer must provide and maintain the Internet connection local to the system as well as an appropriate and compatible network “firewall” with VPN capabilities.



**ATTACHMENT E
2ND YEAR EXTENDED EQUIPMENT
WARRANTY**

May 4, 2012

2012-2013

Knight Security Extended Equipment Warranty

Video - Network Based System

	Quantity	Annual
Network Camera - Fixed	17	4301
Network Camera - PTZ	2	920

Knight Security *SecurePlan*

Network Camera - Fixed	17	3570
Network Camera - PTZ	2	700
SUP for NetDVMS Camera License (per Cam)	19	912

Rental Equipment

Travis County will reimburse the Contractor for rental of any required lifting equipment actually used in the performance of the work. Charges must be supported by invoices issued by the Contractor's suppliers describing the equipment, the dates, and the costs of the rental. A copy of the supplier's invoice will not be required if the cost of any rental period is less than \$25.00 each with combined total of less than \$500.00. Travis County will pay only for the portion of the parts and materials purchased for the assigned job/project approved in the Estimate Form.

Total	\$10403
--------------	----------------

Maintenance/Warranty will start upon sign off of each facility group and will expire in 1 year.

Price is for 2nd year Service Level Agreement (Warranty and Maintenance)

Dallas Office: 10105 Technology Blvd West, Suite 100, Dallas, TX 75220, 214- 350 1632

Houston Office: 25275 Budde Road, Suite 17, Spring, TX 77380, 281- 681-3473

Austin Office: 5321 Industrial Oaks Blvd., Suite 111, Austin TX 78735, 512-892-8801

www.KnightSecurity.com

Security License B-03566 Fire Contractor License ACR-2825

Proven Security Solutions You Can Trust

ATTACHMENT G

Question and Answers for Bid #P120025-GM - External Video Security Cameras

OVERALL BID QUESTIONS

Question 1

What is the warranty period for the OnSSI licenses for your existing cameras and how many existing cameras with OnSSI licenses do you have? OnSSI will require you to prepay forward your existing licenses to match the new.

(Submitted: Nov 9, 2011 10:19:06 AM CST)

Answer

- Travis County holds an OnSSI enterprise license. The number of current existing cameras is security related and has no evident bearing upon this to the RFP. The license from OnSSI is permanent and transferable. However, a maintenance plan, warranty, or software upgrades may vary. If time limits exist that are outside of manufacturer's policy, then the Proposer shall price and explain its price structure to the current county yearly term. (Answered: Nov 23, 2011 10:39:30 AM CST)

Question 2

What is the estimated budget? (Submitted: Nov 9, 2011 2:02:09 PM CST)

Answer

- The County is presently anticipating that this project could run \$55,000 to \$80,000. (Answered: Nov 23, 2011 10:39:30 AM CST)

Question 3

The cameras that are mounted on the side of the building will need to have penetration next to the location. Does the building have special requests for these penetrations? (Submitted: Nov 18, 2011 10:26:45 AM CST)

Answer

- ANSWER PENDING (Answered: Nov 23, 2011 10:39:30 AM CST)
- All penetrations shall be made weatherproof. (Answered: Nov 28, 2011 9:12:54 AM CST)

Question 4

Lift access for the camera mounts on the outside of the building; will there be any requirements for safety? (Submitted: Nov 18, 2011 10:27:19 AM CST)

Answer

- All work is to be performed in accordance with OSHA standards and regulations. (Answered: Nov 23, 2011 10:39:30 AM CST)

Question 5

Conduit on the building to install cameras on the deck area will require approval. Who will be the contact(s) for these approvals/questions? (Submitted: Nov 18, 2011 10:29:40 AM CST)

Answer

- ANSWER PENDING (Answered: Nov 23, 2011 10:39:30 AM CST)
- All work on the roof levels shall be coordinated with Building Management and the County's Project Manager, see below contact information:

Doris Zagst

Sentinel Real Estate Corp. (Building Management)

700 Lavaca St., Suite 900

Austin, TX 78701

Phone: 512-708-0700

Fax: 512-708-0712

Email: srec700@sbcglobal.net

Frank Esparza (Travis County Project Manager for this project)

Phone: 512-854-5226

Email: frank.esparza@co.travis.tx.us (Answered: Nov 28, 2011 9:12:54 AM CST)

Question 6

The conduit in the garage will need to be surface mounted; will there be any requirements on the conduit run locations? (Submitted: Nov 18, 2011 10:30:13 AM CST)

Answer

- ANSWER PENDING (Answered: Nov 23, 2011 10:39:30 AM CST)
- All locations must be approved by Building Management (see answer to Question #5, above). (Answered: Nov 28, 2011 9:12:54 AM CST)

Question 7

Will the ONSSI storage unit have enough storage to handle the HD and Megapixel cameras that will be needed to supply the suspect verification capability requested? (Submitted: Nov 18, 2011 10:31:02 AM CST)

Answer

- Yes. (Answered: Nov 23, 2011 10:39:30 AM CST)

Question 8

On the roof for the PTZ camera, will there be a tie off location for the technicians that will be working on this project for their SAFETY? (Submitted: Nov 18, 2011 10:31:50 AM CST)

Answer

- ANSWER PENDING (Answered: Nov 23, 2011 10:39:30 AM CST)
- According to Building Management, existing roof tie backs and davits were inspected in October, 2010. (Answered: Nov 28, 2011 9:12:54 AM CST)

Question 9

Is there bonding and prevailing wages for this project? (Submitted: Nov 18, 2011 10:32:15 AM CST)

Answer

- This solicitation does not require bonding or prevailing wage stipulations. However, the Contractor will be required to comply with the insurance and liability provisions stated in Part IV General Provisions of the RFP. (Answered: Nov 23, 2011 10:39:30 AM CST)

Question 10

The pictures that were mentioned in the pre-bid meeting for the views that TCCC wants to see - are these available for our use in specifying the correct cameras and how do we access them? (Submitted: Nov 18, 2011 10:33:41 AM CST)

Answer

- The photos that were released to those pre-proposal conference attendees who signed the confidentiality/non-disclosure agreement (NDA) were provided in JPEG format on the supplied media. Any party that was not present, but who wishes to obtain the photos will be required to execute the NDA. These photos are intended to provide conceptual information as to the placement and viewing perspective of the individual camera. The Proposer is expected to utilize this information and the specifications contained in the RFP to propose the camera(s) which meets or exceeds the stated requirements. (Answered: Nov 23, 2011 10:39:30 AM CST)

Question 11

UPS power supplies; what is your requested amount of battery back up time? (Submitted: Nov 18, 2011 10:35:20 AM CST)

Answer

- The County requires a 30 minute minimum backup capability; and, stipulates that only APC equipment, network capability (to include the network card). (Answered: Nov 23, 2011 10:39:30 AM CST)

Question 12

What will be the hours of operation for the project installation? (Submitted: Nov 18, 2011 10:36:35 AM CST)

Answer

- The County's normal working hours are 8:00 a.m. to 5:00 p.m., weekdays. Any work required to be performed outside of those times will require approval by the Travis County project manager. (Answered: Nov 23, 2011 10:39:30 AM CST)

Question 13

Travis County has existing Sony cameras; is this a requirement for the new cameras? (Submitted: Nov 18, 2011 10:37:41 AM CST)

Answer

- No. Beyond the stated specifications, the cameras must be capable of user/password security and be among the list of acceptable cameras for the OnSSI NetDVMS. (Answered: Nov 23, 2011 10:39:30 AM CST)

Question 14

Will Travis County be supplying all the required 110VAC connections? (Submitted: Nov 18, 2011 10:38:14 AM CST)

Answer

- The Contractor shall provide any required electrical connections to its equipment and include any related costs in the proposal. (Answered: Nov 23, 2011 10:39:30 AM CST)

Question 15

Will Travis County be able to supply a list of all the IP addresses before the installation proceeds? (Submitted: Nov 18, 2011 10:38:52 AM CST)

Answer

- Yes. (Answered: Nov 23, 2011 10:39:30 AM CST)

Question 16

Is there an existing communication pathway between the garage and the main building that can be utilized? (Submitted: Nov 18, 2011 3:36:14 PM CST)

Answer

- Conduit and cabling must run from cameras in the garage and then through existing cable tray in the tunnel and communications/security closet. (Answered: Nov 23, 2011 10:39:30 AM CST)

Question 17

It is my understanding all cameras will be controlled by an existing server. Please verify the location and availability of the existing server? (Submitted: Nov 18, 2011 3:37:32 PM CST)

Answer

- The existing server is located in the County's ITS Operations Room located at 509 W. 11th Street. (Answered: Nov 23, 2011 10:39:30 AM CST)

Question 18

Will any new live user workstations be required? If so, where will they be located? (Submitted: Nov 18, 2011 3:38:13 PM CST)

Answer

- None will be required within the scope of this solicitation. (Answered: Nov 23, 2011 10:39:30 AM CST)

Question 19

Will "PoE Plus - 802.3at" switches be able to be sourced by the county? Many new camera models have a high power requirement. (Submitted: Nov 18, 2011 3:39:46 PM CST)

Answer

- ANSWER PENDING (Answered: Nov 23, 2011 10:39:30 AM CST)
- Provide a 24-port switchbox with POE+ (as sold by Cisco) in your proposal. (Answered: Nov 23, 2011 11:18:06 AM CST)

Question 20

Please provide current OnSSI version and licencing information. This is crucial for us proposing the right additional software requirements. (Submitted: Nov 18, 2011 3:42:11 PM CST)

Answer

- NetDVMS 6.5g with an enterprise license. (Answered: Nov 23, 2011 10:39:30 AM CST)

Question 21

Are above ceiling spaces plenum rated? (Submitted: Nov 18, 2011 3:45:20 PM CST)

Answer

- ANSWER PENDING (Answered: Nov 23, 2011 10:39:30 AM CST)
- Yes. (Answered: Nov 28, 2011 9:12:54 AM CST)

Question 22

Pre-Proposal Conference (PPC) Question:

The specifications indicate 14 fixed cameras and 1 PTZ plus the garage. How many cameras are there, actually? (Submitted: Nov 23, 2011 10:56:33 AM CST)

Answer

- As per Attachment C & 700 Lavaca Placement, there are 14 camera locations indicated on the areas surrounding the lower building. However, at location #1 there are actually two cameras to be located here. And, the one PTZ is positioned at location #7 on top of the housing sitting atop the upper-most roof of the building.
- As per Attachment D & 700 Lavaca Garage (2nd Floor), there are 4 camera locations.

Thus, there are a total of 19 cameras. (Answered: Nov 23, 2011 11:18:06 AM CST)

Question 23

PPC:

Are we to provide the cabling; if so, what level & Cat 5, Cat 6? (Submitted: Nov 23, 2011 10:56:57 AM CST)

Answer

- The grade of cable shall be Category 6A. (Answered: Nov 23, 2011 11:18:06 AM CST)

Question 24

PPC:

Can you give us the IDF closet locations associated with this installation? (Submitted: Nov 23, 2011 10:57:18 AM CST)

Answer

- Without your firm having signed a confidentiality/non-disclosure agreement (NDA), we can only supply a general idea as to the locations, layouts, and wiring of the associated IDFs. However, anyone signing the NDA will be provided with existing floor plans of the 1st and 2nd floor, upon request. (Answered: Nov 23, 2011 11:18:06 AM CST)

Question 25

PPC:

Relative to the required OnSSI licenses, will the County want the software upgrade plan for the new licenses? (Submitted: Nov 23, 2011 10:57:48 AM CST)

Answer

- Yes, we will wish to synchronize these licenses with the software license codes of the County's existing licenses. (Answered: Nov 23, 2011 11:18:06 AM CST)

Question 26

PPC:

On Page 41 of the RFP (Attachment A & Pricing Schedule), under Annual Maintenance are you expecting the warranty to cover the first year and maintenance each year afterward? (Submitted: Nov 23, 2011 10:58:26 AM CST)

Answer

- Yes, clearly indicate that warranty will cover the first year and then show the pricing for the maintenance fee for the subsequent years.
As stated in Part III & Special Provisions, Section 3.0 & For each year after the warranty period, the annual license/maintenance fee may not increase more than 3% annually. Offers to keep the fee flat in subsequent years will be looked upon favorably in the scoring of the Proposer's response. (Answered: Nov 23, 2011 11:18:06 AM CST)

Question 27

PPC:

Do you want us to offer a warranty for the existing servers? (Submitted: Nov 23, 2011 10:58:41 AM CST)

Answer

- Generally not. The servers fall under ITS's (Information Technology Services) purview. (Answered: Nov 23, 2011 11:18:06 AM CST)

Question 28

PPC:

Training & How many will be trained and how extensively? (Submitted: Nov 23, 2011 10:59:05 AM CST)

Answer

- We anticipate one classroom session of about 20, or so, Sheriff's Office and Facility Management Department personnel. (Answered: Nov 23, 2011 11:18:06 AM CST)

Question 29

PPC:

In that light, do you require 20 client licenses? (Submitted: Nov 23, 2011 10:59:25 AM CST)

Answer

- To correct what was stated during the pre-proposal conference. A single license is required per camera. Travis County holds an OnSSI enterprise license. (Answered: Nov 23, 2011 11:18:06 AM CST)

Question 30

PPC:

Back to Page 41. Do you want 24X7 coverage for the first year and beyond? (Submitted: Nov 23, 2011 10:59:41 AM CST)

Answer

- Yes. (Answered: Nov 23, 2011 11:18:06 AM CST)

Question 31

PPC:

Do you want a particular camera? (Submitted: Nov 23, 2011 10:59:59 AM CST)

Answer

- No. We indicated the specifications for what we expect the cameras to do. You decide from that and the environment and particular duty assignments to make your best recommendation. (Answered: Nov 23, 2011 11:18:06 AM CST)

Question 32

PPC:

As relates to the specifications for HD or megapixel capability ¿ Is there a suggested minimum or maximum that you are seeking? (Submitted: Nov 23, 2011 11:00:14 AM CST)

Answer

- We do know, based upon current technology, what will best serve our purposes. What you propose we will take under advisement. (Answered: Nov 23, 2011 11:18:06 AM CST)

Question 33

PPC:

What is available as to sleeves or conduit on the roof tops for our use? (Submitted: Nov 23, 2011 11:00:35 AM CST)

Answer

- ANSWER PENDING. (Answered: Nov 23, 2011 11:18:06 AM CST)
- See answer to Question #5 above. (Answered: Nov 28, 2011 9:12:54 AM CST)

Question 34

PPC:

Do you want us to offer a warranty for the existing servers? (Submitted: Nov 23, 2011 11:00:59 AM CST)

Answer

- Generally not. The servers fall under ITS¿s (Information Technology Services) purview. (Answered: Nov 23, 2011 11:18:06 AM CST)

Question 35

PPC:

Does the proposed installer have to have OnSSI certification? (Submitted: Nov 23, 2011 11:01:17 AM CST)

Answer

- Yes. The installer must be an OnSSI certified integrator. (Answered: Nov 23, 2011 11:18:06 AM CST)

Question 36

PPC:

How many OnSSI licenses do you currently have? (Submitted: Nov 23, 2011 11:01:38 AM CST)

Answer

- As previously stated, Travis County holds an OnSSI enterprise license. (Answered: Nov 23, 2011 11:18:06 AM CST)

Question 37

PPC:

Do we need to supply any server hardware? (Submitted: Nov 23, 2011 11:01:54 AM CST)

Answer

- No. (Answered: Nov 23, 2011 11:18:06 AM CST)

Question 38

PPC:

Related to POE, is everything rack mounted? (Submitted: Nov 23, 2011 11:02:09 AM CST)

Answer

- Yes. (Answered: Nov 23, 2011 11:18:06 AM CST)

Question 39

PPC:

Can you tell us about the locations of the IDFs? (Submitted: Nov 23, 2011 11:02:28 AM CST)

Answer

- Generally speaking, there is one IDF on the first floor, two on the second floor, and one on the 15th floor. There is not one currently in the Garage. The one for the Garage will most likely be located in an existing room that is in the pedestrian tunnel located on the lower level between 700 Lavaca and the Garage. We estimate that the distance to the farthest intended camera location is less than 100m; but the Proposer is responsible for confirming that the distance is or is not within maximum allowance. (Answered: Nov 23, 2011 11:18:06 AM CST)

Question 40

PPC:

Do we need to provide any POE extenders? (Submitted: Nov 23, 2011 11:02:47 AM CST)

Answer

- That will be up to the Proposer to determine. (Answered: Nov 23, 2011 11:18:06 AM CST)

Question 41

PPC:

Do we need to supply manufacturers' specifications (supplementals)? (Submitted: Nov 23, 2011 11:03:06 AM CST)

Answer

- Yes, with the proposal. (Answered: Nov 23, 2011 11:18:06 AM CST)

Question 42

When does the County expect to have this work completed? (Submitted: Nov 23, 2011 11:03:21 AM CST)

Answer

- It is expected that work will commence by February and complete prior to the first of March, 2012. (Answered: Nov 23, 2011 11:18:06 AM CST)

[Print](#)

[Close](#)

ATTACHMENT B**Non-Disclosure and Confidentiality Agreement for
Documents Comprising the ITS Security Requirements**

Instructions: After signing this document, please return to George Monnat via Fax at 512-854-9185 or via email at george.monnat@co.travis.tx.us. Upon receipt of the signed document, the requested information will be forwarded. The original signed NDA should be returned with vendor's RFP response.

1. In the interest of obtaining all information relevant for purposes of providing the requested goods and/or services in connection with RFP #P120025-GM, Security Control System (the "RFP"), the undersigned¹ hereby agrees, to the extent permitted by law, to treat confidential any and all information furnished to the undersigned, but in any event the information contained in the specific documents listed below (the "Confidential Information").

The undersigned agrees to treat the Confidential Information as confidential during their review of the RFP and any associated documents; during formulation and delivery of a formal response to the RFP; and during any other associated tasks or functions related to this phase of the Travis County procurement process (including negotiations of any modifications, amendments, addenda or extensions of or to the RFP) and in perpetuity thereafter.

2. The undersigned acknowledges that Travis County has developed the Confidential Information and that Travis County considers such information confidential and proprietary. The undersigned shall not, without first obtaining County's prior written consent, disclose the Confidential Information to any person or entity other than to the employees, counsel and accountants of the undersigned or duplicate the Confidential Information in whole or in part.
3. The sole purposes for which the undersigned may disclose the Confidential Information to its officers, employees and agents shall be limited to: (i) the evaluation of a continuing and/or further business relationship with Travis County; and (ii) in the event the RFP and/or subsequent Contract is modified, amended, or extended, the fulfillment of its contractual obligations to Travis County.
4. The undersigned shall maintain the confidentiality of the Confidential Information, including instructing its officers, employees and agents regarding the obligations of the undersigned under this Non-Disclosure and Confidentiality Agreement and to take all other reasonable precautions to prevent disclosure of the Confidential Information.

¹ As used in this Non-Disclosure and Confidentiality Agreement, the term "the undersigned" includes the officers, employees and agents of the vendor receiving the documents listed herein.

5. The undersigned acknowledges and understands that the documents listed below will change over time to accommodate the needs of Travis County. Travis County reserves the right to revise (by way of modification, deletion or supplementation) the documents and the Confidential Information contained therein and, following such revision, agrees to provide the updated version of any revised document to the undersigned as soon as practicable. The undersigned agrees that this Non-Disclosure and Confidentiality Agreement shall apply to current and future versions of the documents listed below.

6. In the event the undersigned chooses not to respond to the RFP, or is not the successful proposer, the undersigned agrees to destroy all copies of the Confidential Information immediately.

7. By furnishing the Confidential Information to the undersigned pursuant to this Non-Disclosure and Confidentiality Agreement, Travis County does not waive or otherwise relinquish any right of non-disclosure or other privilege available to it under the Texas Public Information Act or other applicable statute, law or regulation.

By: Bob Minchew

Title: Director

Company Name: Knight Security Systems

Date: 11-17-2011

Email address: BMinchew@KnightSecurity.com

**Documents Currently Comprising the Travis County
Information Security Policies and Standards**

Ref #	Document Title
G00	Information Security Program Charter
P01	Asset Identification & Classification Policy
P01.S01	Information Classification Standard
P01.S02	Information Labeling Standard
P02	Asset Protection Policy
P02.S01	Access Control Standard
P02.S02	Remote Access Standard
P02.S02.01	Remote Access Standard For Third Parties
P02.S03	Encryption Standard